



**We put
laboratory
space to
work.**

Commercial Catalogue

**Laboratory & Cleanroom
Environments**

Wel- Come

Wachauf Industries' commercial catalogue and brochure for laboratory and cleanroom spaces, based on InterMetro Industries versatile, unique, and value-adding produce line.

Lab Carts
Utility Carts
Shelving
Gowning Room Racks
High Density Storage
Worktables
Security
Lab Workstations

www.metro.com

Table Of Contents

1	Lab & Utility Carts	4
	Streamline your workflow with versatile, durable carts designed for efficiency and mobility to safely and comfortably move more of your product.	
2	Super Erecta® Shelving	10
	Optimize your space with our robust, adaptable shelving system that meets all your specific storage needs.	
3	Super Adjustable™ Shelving	16
	Experience ultimate flexibility with easy "no-tool" adjustments to shelving that accommodates changing product storage requirements.	
4	MetroMax i®	19
	Benefit from superior strength, safety, cleanability, and corrosion resistance with our premium polymer shelving solution.	
5	Solid Shelving Units	22
	Maximize your storage potential with our wide range of reliable and customizable solid shelving units tailored to your needs.	
6	Metro Shelving's Space Optimization	26
	Transform your space with innovative solutions designed for maximum efficiency and organization, giving you <i>more space for more production</i> .	
7	Security Storage	30
	Keep your valuable items safe and secure during storage and transport with our top-of-the-line security storage solutions.	
8	TableWorx™	36
	Increase output in your operating and production spaces with ergonomic and customizable workstations built for any task.	
9	Ready-to-Implement Laboratory Solutions	43
	Equip your laboratory with turnkey solutions that are ready for immediate use and optimal performance.	

Metro Shelving

Lab & Utility Carts

01

Designed for your transport needs...
making every step count.

Metro's wide range of general-purpose and specialty carts includes autoclavable racks, carts for transporting chemicals, glass vessels, high-performance liquid chromatography (HPLC) Carts and much more, all made from high quality-stainless steel and polymer materials.

This is myCart™ ... get your own.

Shelves are made of durable, chemical-resistant high-density polyethylene, offering excellent resistance to most acids and bases. They can also feature built-in **Microban®** antimicrobial protection to inhibit the growth of bacteria, mold, and mildew.

MyCart Series Utility Carts

- › Available in 2-shelf and 3-shelf configurations with a 7/16" (11 mm) deep ship's edge lip around shelf perimeter.
- › MY1627 and MY2030 Base Model specs: Chrome posts, 4" non-marking swivel casters. 150 lbs. (68 kg) capacity per shelf.
- › MY2636 Base Model specs: Chrome posts, 5" swivel resilient rubber casters, 200 lbs. (90 kg) capacity per shelf.

Deep Ledge Utility Carts

- › 2-shelf and 3-shelf models are easy-to-clean and corrosion proof.
- › Shelves provide a 2 3/4" (70 mm) ledge to contain products and spills.

Grade A Pharma Carts

MetroMax i® Lab & Lab Storage Carts

Metro's Lab Cart line, including the General Lab Cart, Chemical Cart, and Mobile Desk, offers high corrosion resistance, 5" (125 mm) smooth-rolling casters, and adjustable shelves set in 1" (25 mm) increments.

- › **Corrosion Proof and Microban® Antimicrobial Protection**
- › **Easy-to-Clean and Easy-to-Maintain**
- › **Flexible and Modular**

MetroMax i® Utility Carts

- › Removable 2-shelf and 3-shelf models available for easy cleaning.
- › Open design allows for our full line of accessories to be used.
- › Weight capacity 600 lbs. (272 kg) per cart.



Move,
store &
secure
what
matters
most.

MyCart Series Utility Carts

inch (W x L x H)	mm (W x L x H)	Description	Cart in lbs	Cart in kg	Approx. Pkd. Wt. lbs	Approx. Pkd. Wt. kg	Cat. No. Gray	Cat. No. Black
18 3/8 x 31 7/8 x 35 3/8	465 x 799 x 899	2-shelf unit Base Model	300	136.4	27 1/2	12.5	MY1627-24G	MY1627-24BL
18 3/8 x 31 7/8 x 35 3/8	465 x 799 x 899	3-shelf unit Base Model	400	181.1	33	15	MY1627-34G	MY1627-34BL
23 1/2 x 34 3/8 x 35 3/8	597 x 873 x 899	2-shelf unit Base Model	300	136.4	34 1/2	15.7	MY2030-24G	MY2030-24BL
23 1/2 x 34 3/8 x 35 3/8	597 x 873 x 899	3-shelf unit Base Model	400	181.8	43	19.5	MY2030-34G	MY2030-34BL
27 7/8 x 40 1/4 x 36 5/8	703 x 1022 x 930	2-shelf unit Base Model	400	181.8	40 1/2	18.4	MY2636-25G	MY2636-25BL
27 7/8 x 40 1/4 x 36 5/8	703 x 1022 x 930	3-shelf unit Base Model	500	227.3	52	23.6	MY2636-35G	MY2636-35BL

Deep Ledge Utility Carts

inch (W x L x H)	mm (W x L x H)	Description	Cart in lbs	Cart in kg	Approx. Pkd. Wt. lbs	Approx. Pkd. Wt. kg	Cat. No. Blue	Cat. No. Gray	Cat. No. Black
21 1/2 x 32 3/4 x 41	546.1 x 831.9 x 1041.4	2-shelf unit	29	136.4	27 1/2	12.5	MY1627-24G	MY1627-24BL	BC2030-2DBL
21 1/2 x 32 3/4 x 41	546.1 x 831.9 x 1041.4	3-shelf unit	37 1/2	181.1	33	15	MY1627-34G	MY1627-34BL	BC2030-3DBL
27 x 38 3/4 x 41	685.8 x 984.3 x 1041.4	2-shelf unit	35	181.8	40 1/2	18.4	MY2636-25G	MY2636-25BL	BC2636-2DBL
27 x 38 3/4 x 41	685.8 x 984.3 x 1041.4	3-shelf unit	46 1/2	227.3	52	23.6	MY2636-35G	MY2636-35BL	BC2636-3DBL

MyCart and Deep Ledge Utility Carts with Microban®

inch (W x L x H)	mm (W x L x H)	Description	Approx. Pkd. Wt. lbs	Approx. Pkd. Wt. kg	Cat. No. Blue
18 3/8 x 31 7/8 x 35 3/8	465 x 799 x 899	2-shelf unit Base Model	21 1/2	136.4	MY1627-24BU
18 3/8 x 31 7/8 x 35 3/8	465 x 799 x 899	3-shelf unit Base Model	33	181.1	MY1627-34BU
23 1/2 x 34 3/8 x 35 3/8	597 x 873 x 899	2-shelf unit Base Model	34 1/2	136.4	MY2030-24BU
23 1/2 x 34 3/8 x 35 3/8	597 x 873 x 899	3-shelf unit Base Model	43	181.8	MY2030-34BU
27 7/8 x 40 1/4 x 36 5/8	703 x 1022 x 930	2-shelf unit Base Model	52	181.8	MY2636-25BU
27 7/8 x 40 1/4 x 36 5/8	703 x 1022 x 930	3-shelf unit Base Model	40 1/2	227.3	MY2636-35BU
21 1/2 x 32 3/4 x 41	546 x 832 x 1041	2-shelf Deep Ledge	29	13.1	BC2030-2DMB
21 1/2 x 32 3/4 x 41	546 x 832 x 1041	2-shelf Deep Ledge	37 1/2	17.0	BC2030-3DMB

MetroMax i® UtilityCarts

inch (W x L x H)	mm (W x L x H)	Description	Cat. No.
18 x 30 x 40	457 x 760 x 1015	2-shelf	MXUC1830G-25
24 x 36 x 40	610 x 914 x 1015	2-shelf	MXUC2436G-25
18 x 30 x 40	457 x 760 x 1015	3-shelf	MXUC2436G-25
24 x 36 x 40	610 x 914 x 1015	3-shelf	MXUC2436G-35

MetroMax i® Lab Carts

inch (W x L x H)	mm (W x L x H)	Description	Cart in lbs	Cart in kg	Approx. Pkd. Wt. lbs	Approx. Pkd. Wt. kg	Cat. No.
18 x 36 x 40	457 x 914 x 1016	General Lab Cart	600	273	43	19.5	LABX3
18 x 36 x 40	457 x 914 x 1016	Chemical Cart	600	273	49	22.2	CHEMX3
18 x 36 x 40	457 x 914 x 1016	Mobile Desk	600	273	55	24.9	MDSX3



2-Shelf myCart Series Cart



3-Shelf Deep Ledge Utility Cart



General Lab Cart
(Casters included)



3-Shelf myCart Series Cart
(with Microban®)



MetroMax i® UtilityCart



Mobile Desk
(Casters included)



Chemical Cart
(Casters included)

MetroMax Glassware Carts

MetroMax i® Glassware Carts

Glassware carts are built primarily from MetroMax advanced polymers, providing lifetime corrosion protection. Choose from a wide range of accessories, including all polymer casters for maximum corrosion resistance and premium performance.

- Two-basket and four-basket capacity glassware solutions are offered in a space-saving 18" x 36" (457 x 914 mm) footprint.
- Solid MetroMax i® bottom shelf provides spill retention and can be removed from shelf frame for easy cleaning.
- Choose from a wide range of accessories, including all-polymer casters, for maximum corrosion resistance and premium performance.



Units listed below do not include casters. Part #5PCX & 5PCBX (two brake, two swivel) casters are recommended for superior lifetime performance. Order casters separately.

inch (W x L x H)	mm (W x L x H)	Description	Cat. No.	Approx. Pkd. Wt. lbs	Approx. Pkd. Wt. kg	Cat. No.
18 x 36 x 40	457 x 914 x 1016	2-basket unit	MXUC1830G-25	38	17	GWBX3-1
18 x 36 x 60	457 x 914 x 1524	4-basket unit	MXUC1830G2-35	83	37	GWBX3-2
18 x 36 x 40	457 x 914 x 1016	2-tote kit unit	MXUC1830G-35	36	16.3	GWTX3-1
18 x 36 x 60	457 x 914 x 1524	4-tote kit unit	MXUC2436G2-35	101	46	GWTX3-2

Accessories

inch (W x L x H)	mm (W x L x H)	Description	Approx. Pkd. Wt. lbs	Approx. Pkd. Wt. kg	Cat. No.
18 x 36 x 32	457 x 914 x 889	Clear Cart Cover - short unit	2.5	1.1	GWCVC41
18 x 36 x 52	457 x 914 x 1320	Clear Cart Cover - tall unit	3.5	1.6	GWCVC62
18 x 36 x 32	457 x 914 x 889	Blue Cart Cover - short unit	2.5	1.1	GWSVC41
18 x 36 x 52	457 x 914 x 1320	Blue Cart Cover - tall unit	3.5	1.6	GWSVC62
6 x 1 1/2 (L x B)	152 x 32	Color Shelf Marker - red	2.5	1.1	CSM6-R
6 x 1 1/2 (L x B)	152 x 32	Color Shelf Marker - blue	3.5	1.6	CSM6-B
		Tote Glassware Transport Kit	38	17	GWOLYKIT
24 x 48 x 81	24 x 48 x 81	Vinyl-coated Baskets (2)	8	3.6	GWBSKT36

By combining standard MetroMax i® components, including MetroMax i® baskets, a custom glassware cart can be created.



GWBX3-1
(with blue cart cover and casters)



GWTX3-1
(Includes two tote boxes.
Casters and additional tote boxes sold separately)

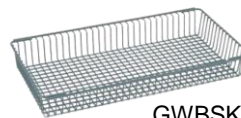

GWBSKT36



GWBX3-2
shown with GWTX3-1



GWBX3-1
(with clear cart cover and casters)

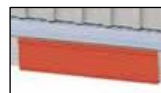

CSM6-R
Red shelf markers can be used to designate unclean glassware



CSM6-B
Blue shelf markers can be used to designate clean glassware

Lab Carts – HPLC

MetroMax i® High-Performance Liquid Chromatography (HPLC) Carts

- › HPLC carts contribute to greater benchtop productivity.
- › Mobilize and stack HPLC equipment on carts to maximize valuable lab space.
- › Avoid crowding valuable bench top space with High-Performance Liquid Chromatography (HPLC) or other analytical equipment.

HPLC Models - 4 Shelf Models (Casters not included*)

inch (W x L x H)	mm (W x L x H)	Description	Approx. Pkd. Wt. lbs	Approx. Pkd. Wt. kg	Cat. No.
24 x 30 x 81	610 x 760 x 228	4-shelf unit Single Experiment Cart	70	32	HPLC3X3
24 x 48 x 81	610 x 1219 x 2288	4-shelf unit Double Experiment Cart	101	46	HPLC4X3

HPLC Models - 5 Shelf Models (Casters included)

inch (W x L x H)	mm (W x L x H)	Description	Approx. Pkd. Wt. lbs	Approx. Pkd. Wt. kg	Cat. No.
24 x 30 x 81	610 x 760 x 228	5-shelf unit Single Experiment Cart	89.5	40.6	HPLC1X3
24 x 48 x 81	610 x 1219 x 2288	5-shelf unit Double Experiment Cart	114.5	51.9	HPLC2X3

Accessories

Description	Approx. Pkd. Wt. lbs	Approx. Pkd. Wt. kg	Cat. No.
Post-mount swing arm for flat monitor	4.5	2.0	FMAX
Post-mount cable/tube management clips	1.0	.45	TMX

Slide-out Keyboard Shelf

Epoxy-coated keyboard shelf provides high level of corrosion resistance. Designed to fit both 18" (457 mm) and 24" (610 mm) wide MetroMax i® shelves. Keyboard shelf loading should not exceed 10 lbs. (45.8 kg).

Dimensions (W x L x H): 16" x 26 1/2" x 5" (406 x 673 x 127 mm). Cat. No. KBX.

Flat Monitor Mounting Kit

Unique mounting bracket and cross-bar design permits flat monitor to be mounted on MetroMax i® units. Flat monitor can be mounted between two MetroMax i® posts, either in back or front of unit. Mounting bracket loading should not exceed 30 lbs (14 kg). VESA mounting plates included with bracket.

Note: For flat monitor mounting on MetroMax i® order either Cat. No. FM30X3, FM36X3 or FM48X3 (Cross-bar and mounting bracket included). For flat monitor mounting on Mobile Desk order Cat. No.FMBX.

Cross-Bar Dimensions (W x L x H):

Cat. No. FM30X3 (Bracket and Cross Bar) – 2 1/8" x 30" x 3" (54 x 762 x 76 mm)

Cat. No. FM36X3 (Bracket and Cross Bar) – 2 1/8" x 36" x 3" (54 x 914 x 76 mm)

Cat. No. FM48X3 (Bracket and Cross Bar) – 2 1/8" x 48" x 3" (54 x 1219 x 76 mm)

Cat. No. FMBX (Mounting Bracket only)

Bracket Dimensions (W x L x H):

3 7/16" x 8 13/16" x 5 3/4" (87 x 223 x 146 mm) (Cat. No. FMBX)

Power Strip

Six outlet power strip, featuring surge protection, mounts flush with any MetroMax i® shelf frame. Power strip is UL approved. Gray power strip comes with 6 foot (1829 mm) long cord.

Dimensions (W x L x H): 2 1/4" x 13" x 4 1/4" (57 x 330 x 108 mm). Cat. No. PSX.

Usage instruction: When flat monitor mounting kit is in use, please remove flat monitor from cross bar before cart transport.

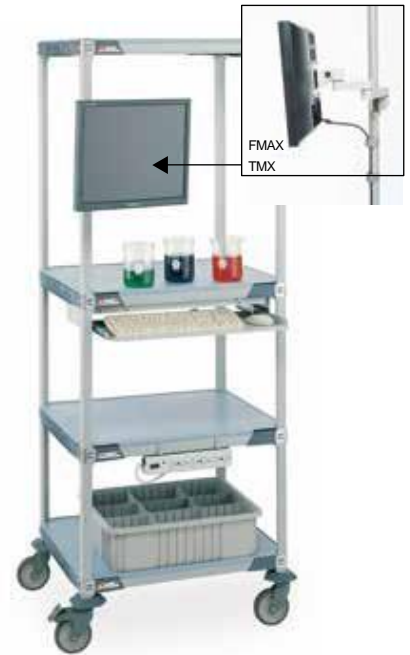

HPLC3X3 (Shown with accessories and casters)



KBX

Usage Instruction

- When flat monitor mounting kit is in use, please remove flat monitor from cross bar before cart transport.



FM30X3

FM36X3

FM48X3



PSX

Standard-Duty Utility Carts

MW Standard-Duty Utility Carts

- › A durable, dependable transport solution that's easy to maneuver.
- › Highly rigid Super Erecta® construction lets you easily adjust shelves at 1" (25 mm) increments.
- › Each cart consists of 2 handles, indicated number of shelves, and casters. 18" (457 mm) wide carts have 4" (102 mm) light-duty casters and are 38" (965 mm) high. 21" (530 mm) and 24" (610 mm) wide carts have 5" (127 mm) light-duty casters providing 375 lbs. (171 kg) of load capacity and are 39" (990 mm) high.

MW100 Series — 2 Solid Shelves

inch (W x L x H)	mm (W x L x H)	Approx. Pkd. Wt. lbs	Approx. Pkd. Wt. kg	Shelf Material	Handles	Cat. No.
18 x 24	457 x 610	40	18.1	Stainless Steel	Stainless Steel	MW103
18 x 30	457 x 760	45	20.4	Stainless Steel	Stainless Steel	MW104
18 x 36	457 x 914	48	21.8	Stainless Steel	Stainless Steel	MW105
21 x 36	530 x 914	54	24.5	Stainless Steel	Stainless Steel	MW106
24 x 36	610 x 914	60	27.2	Stainless Steel	Stainless Steel	MW108

MW200 Series — 3 Solid Shelves

inch (W x L x H)	mm (W x L x H)	Approx. Pkd. Wt. lbs	Approx. Pkd. Wt. kg	Shelf Material	Handles	Cat. No.
18 x 24	457 x 610	48	21.8	Stainless Steel	Stainless Steel	MW203
18 x 30	457 x 760	53	24	Stainless Steel	Stainless Steel	MW204
18 x 36	457 x 914	59	26.8	Stainless Steel	Stainless Steel	MW205
21 x 36	530 x 914	66	29.9	Stainless Steel	Stainless Steel	MW206
24 x 36	610 x 914	74	33.6	Stainless Steel	Stainless Steel	MW208

MW400 Series — 1 Solid, 2 Wire Shelves

inch (W x L x H)	mm (W x L x H)	Approx. Pkd. Wt. lbs	Approx. Pkd. Wt. kg	Shelf Material	Handles	Cat. No.
18 x 24	457 x 610	43	19.5	Stainless Steel, Chrome	Chrome	MW401
18 x 30	457 x 760	47	21.3	Stainless Steel, Chrome	Chrome	MW402
18 x 36	457 x 914	52	23.6	Stainless Steel, Chrome	Chrome	MW403
21 x 36	530 x 914	59	26.8	Stainless Steel, Chrome	Chrome	MW404
24 x 36	610 x 914	65	29.5	Stainless Steel, Chrome	Chrome	MW406

MW600 Series — 2 Wire Shelves

inch (W x L x H)	mm (W x L x H)	Approx. Pkd. Wt. lbs	Approx. Pkd. Wt. kg	Shelf Material	Handles	Cat. No.
18 x 24	457 x 610	43	19.5	Stainless Steel, Chrome	Chrome	MW601
18 x 30	457 x 760	47	21.3	Stainless Steel, Chrome	Chrome	MW602
18 x 36	457 x 914	52	23.6	Stainless Steel, Chrome	Chrome	MW603
21 x 36	530 x 914	59	26.8	Stainless Steel, Chrome	Chrome	MW604
24 x 36	610 x 914	65	29.5	Stainless Steel, Chrome	Chrome	MW605
18 x 24	457 x 610	43	19.5	Stainless Steel, Chrome	Chrome	MW606
18 x 30	457 x 760	47	21.3	Stainless Steel, Chrome	Chrome	MW607
18 x 36	457 x 914	52	23.6	Stainless Steel, Chrome	Chrome	MW608
21 x 36	530 x 914	59	26.8	Stainless Steel, Chrome	Chrome	MW611
24 x 36	610 x 914	65	29.5	Stainless Steel, Chrome	Chrome	MW612

MW700 Series — 3 Wire Shelves

inch (W x L x H)	mm (W x L x H)	Approx. Pkd. Wt. lbs	Approx. Pkd. Wt. kg	Shelf Material	Handles	Cat. No.
18 x 24	457 x 610	39	17.6	Chrome	Chrome	MW701
18 x 24	457 x 610	38	17.2	Stainless Steel	Stainless Steel	MW702
18 x 30	457 x 760	43	19.5	Chrome	Chrome	MW703
18 x 30	457 x 760	42	19.1	Stainless Steel	Stainless Steel	MW704
18 x 36	457 x 914	47	21.3	Chrome	Chrome	MW705
18 x 36	457 x 914	45	20.4	Stainless Steel	Stainless Steel	MW705
21 x 36	530 x 914	50	22.7	Chrome	Chrome	MW707
21 x 36	530 x 914	50	22.7	Stainless Steel	Stainless Steel	MW708
24 x 36	610 x 914	60	27.7	Chrome	Chrome	MW711
24 x 36	610 x 914	57	25.9	Stainless Steel	Stainless Steel	MW712



MW100 Series



MW200 Series



MW400 Series



MW600 Series



MW700 Series

Standard-Duty Utility Carts – Accessories

Stem Casters

Use with Super Erecta® posts and shelves to create a mobile shelving unit to meet your special needs. Stem casters are shipped with donut bumper at no additional charge.

Wheel Diameter inch	Wheel Diameter mm	Face inch	Face mm	Load Rating lbs	Load Rating kg	Type	Wheel Tread	Approx. Pkd. Wt. lbs	Approx. Pkd. Wt. kg	Cat. No.
4	102	1/2	12	125	56	Stem/Swivel	Resilient	1 1/2	0.6	4LD
5	127	1/2	12	125	56	Stem/Swivel	Resilient	2	0.9	5LD
5	127	1 1/4	32	200	90	Stem/Swivel	Resilient	2 1/2	1.1	5M
5	127	1 1/4	32	200	90	Stem/Brake	Resilient	2 5/8	1.2	5MB
5	127	1 1/4	32	200	90	Stem/Rigid	Resilient	3 1/2	1.5	5MR
5	127	1 1/4	32	250	111	Stem/Swivel	High Modulus Donut	2 1/2	1.1	5MDA
5	127	1 1/4	32	250	111	Stem/Brake	High Modulus Donut	2 5/8	1.17	5MDBA
5	127	1 1/4	32	250	111	Stem/Rigid	High Modulus Donut	2 3/8	1.08	5MDRA
5	127	1 1/4	32	300	135	Stem/Swivel	Polyurethane	2 1/8	0.94	5MP
5	127	1 1/4	32	300	135	Stem/Brake	Polyurethane	2 1/4	1	5MPB
5	127	1 1/4	32	300	135	Stem/Rigid	Polyurethane	2	0.9	5MPR
6	152	1 1/4	32	300	135	Stem/Swivel	Polyurethane	2 1/4	1.08	6MP
6	152	1 1/4	32	300	135	Stem/Brake	Polyurethane	2 1/2	0.94	6MPB
6	152	1 1/4	32	300	135	Stem/Rigid	Polyurethane	2 1/4	1	6MPR



5M

5MB

Note 1: Rigid casters are held in position by a connecting channel. When ordering rigid casters, shelf width must be known.

Note 2: Load Height for all 5M and 5MP casters — 6 3/32" ± 1/16" (155 ± 1.5 mm).

Note 3: Load Height for 4LD caster — 4 9/16" ± 1/16" (118 ± 1.5 mm).

Note 4: Load Height for 5LD caster — 5 5/16" ± 1/16" (143 ± 1.5 mm).

Note 5: Brakes are foot-operated.

Rigid stem casters are often ordered two per unit for improved tracking and handling. Rigid caster channels are provided with each two rigid stem casters at no charge.

Stainless Steel Cart-Washable Stem Casters

Stem casters are shipped with donut bumpers at no extra charge.

Wheel Diameter inch	Wheel Diameter mm	Face inch	Face mm	Load Rating lbs	Load Rating kg	Type	Wheel Tread	Approx. Pkd. Wt. lbs	Approx. Pkd. Wt. kg	Cat. No.
5	127	1 1/4	32	150	68	Swivel	High Modulus	2 1/2	1.1	5MDGSA
5	127	1 1/4	32	150	68	Brake	High Modulus Donut	2 5/8	1.17	5MDBGSA
5	127	1 1/4	32	150	68	Rigid	High Modulus Donut	2 3/8	1.08	5MDRGSA
5	127	1 1/4	32	300	135	Swivel	Polyurethane	2 1/8	0.94	5MPGSA
5	127	1 1/4	32	300	135	Brake	Polyurethane	2 1/4	1	5MPBGSA
5	127	1 1/4	32	300	135	Rigid	Polyurethane	2	0.9	5MPRGSA

Note 1: Rigid casters are held in position by a connecting channel. When ordering rigid casters, shelf width must be known.

Note 2: Load Height 6 3/32" ± 1/16" (155 ± 1.5 mm).

Note 3: All casters are grease sealed with zerk fittings in swivel and axle.

Note 4: Brakes are foot-operated.



5MDGSA



Donut Bumper

Donut Bumpers

Diameter inch	Diameter mm	Height inch	Height mm	Cat. No.
3 1/2	89	3/4	19	9992DB*
5 1/2	140	1 3/16	21	9992N

* Included with each Super Erecta® stem caster as noted above.



Superior materials and design for every application.

Metro Shelving Super Erecta®

Metro Fact:

Genuine Metro!

Metro created the original post-based shelving unit in 1965. Today, Metro Super Erecta Shelving is recognized worldwide as the most popular commercial shelving system ever.

02

The original wire storage system.

A storage system that defines the extent of space, Super Erecta's revolutionary concept was fresh and innovative from its start. It has continued to evolve, with nearly 100 highly specialized accessories, aimed at meeting the diversity of today's challenges.

- › **Adjustable:** Shelves can be repositioned at precise 1" (25 mm) increments along the length of the numbered posts.
- › **Unique Design:** Open-wire design minimizes dust accumulation, allows a free circulation of air, and greater visibility of stored items.
- › **Mobile:** Full choice of caster types available for mobile applications.



Super Erecta® – Shelving Units & Accessories

Wire Shelves

Packaging: Super Erecta Wire Shelves are packaged 4 to a carton (shelves sold separately) except 60" (1524 mm) and 72" (1829 mm) lengths and 30" (760 mm) and 36" (914 mm) widths, which are packaged 2 to a carton (shelves sold separately). Plastic sleeves and wedges are included with each shelf.

Inch (W x L)	mm (W x L)	Approx. Pkd. Wt. lbs	Approx. Pkd. Wt. kg	Cat. No Chrome	Cat. No Metroseal 3 with Microban	Cat. No Stainless
14 x 24	355 x 610	6	2.7	1424NC	1424NK3	1424NS
14 x 30	355 x 760	7	3.2	1430NC	1430NK3	1430NS
14 x 36	355 x 914	8	3.6	1436NC	1436NK3	1436NS
14 x 42	355 x 1066	9.5	4.3	1442NC	1442NK3	1442NS
14 x 48	355 x 1220	10.5	4.7	1448NC	1448NK3	1448NS
14 x 60	355 x 1524	14	6.3	1460NC	1460NK3	1460NS
14 x 72	355 x 1829	17	7.7	1472NC	1472NK3	1472NS
18 x 24	457 x 610	7	3.2	1824NC	1824NK3	1824NS
18 x 30	457 x 760	8	3.6	1830NC	1830NK3	1830NS
18 x 36	457 x 914	9.5	4.3	1836NC	1836NK3	1836NS
18 x 42	457 x 1066	11	5	1842NC	1842NK3	1842NS
18 x 48	457 x 1219	12	5.4	1848NC	1848NK3	1848NS
18 x 54	457 x 1370	14.5	6.6	1854NC	1854NK3	1854NS
18 x 60	457 x 1524	17	7.7	1860NC	1860NK3	1860NS
18 x 72	457 x 1829	20	9.1	1872NC	1872NK3	1872NS
21 x 24	530 x 610	8	3.6	2124NC	2124NK3	2124NS
21 x 30	530 x 760	9	4.1	2130NC	2130NK3	2130NS
21 x 36	530 x 914	11	5	2136NC	2136NK3	2136NS
21 x 42	530 x 1066	12	5.4	2142NC	2142NK3	2142NS
21 x 48	530 x 1219	14	6.4	2148NC	2148NK3	2148NS
21 x 54	530 x 1370	16	7.3	2154NC	2154NK3	2154NS
21 x 60	530 x 1524	18	8.2	2160NC	2160NK3	2160NS
21 x 72	530 x 1829	24	10.9	2172NC	2172NK3	2172NS
24 x 24	610 x 610	9	4.1	2424NC	2424NK3	2424NS
24 x 30	610 x 760	11	5	2430NC	2430NK3	2430NS
24 x 36	610 x 914	13	5.9	2436NC	2436NK3	2436NS
24 x 42	610 x 1066	15	6.8	2442NC	2442NK3	2442NS
24 x 48	610 x 1219	16	7.3	2448NC	2448NK3	2448NS
24 x 54	610 x 1370	19	8.6	2454NC	2454NK3	2454NS
24 x 60	610 x 1524	21	9.5	2460NC	2460NK3	2460NS
24 x 72	610 x 1829	26	11.8	2472NC	2472NK3	2472NS
36 x 36	910 x 914	18	8.2	3636NC	3636NK3	3636NS
36 x 48	910 x 1219	23	10.4	3648NC	3648NK3	3648NS
36 x 60	910 x 1524	29	13.1	3660NC	3660NK3	3660NS
36 x 72	910 x 1829	34.5	15.4	3672NC	3672NK3	3672NS

Note: With 14" (355 mm) shelving, foot plates must be used on freestanding units; on mobile units, maximum post height is 54" (1370 mm). It is not recommended to use 14" (355 mm) shelving with posts higher than 74" (1880 mm).

Note: The actual length of the shelves is 1/8" (3.2 mm) shorter than the nominal dimension shown. The actual depth of the shelves is 1/8" (3.2 mm) greater than the nominal dimension shown.

Note: Metroseal 3 is not cart-washable.

Note: Super Erecta wire shelves up to 48" (1219 mm) long can hold up to 800 lbs. (363 kg) per shelf. Shelves longer than 48" (1219 mm) or deeper than 24" (610 mm) can hold up to 600 lbs. (272 kg) per shelf.

SiteSelect™ Posts

Stationary Super Erecta® SiteSelect posts are fitted with adjustable leveling bolts to compensate for uneven surfaces. Mobile posts come without leveling bolt assembly to accommodate stem casters. Special length posts are available. Shelves and posts are carton but sold packed separately.

Stationary							Mobile					
Height ¹ inch	Height ¹ mm	Approx. Pkd. Wt. lbs	Approx. Pkd. Wt. kg	Cat. No Chrome	Cat. No Metroseal 3 with Microban	Cat. No Stainless ²	Approx. Wt. lbs	Approx. Wt. kg	Cat. No Chrome	Cat. No Metroseal 3 with Microban	Cat. No Stainless ²	
7 1/2	191	1/2	0.3	7P	—	—	—	—	7UP	—	—	
14 1/2	370	1	0.5	13P	13PK3	13PS	1	0.5	13UP	13UPK3	13UPS	
27 1/2	699	1 1/4	0.75	27P	—	27PS	1 1/4	0.75	27UP	—	27UPS	
34 1/2	875	2	0.9	33P	33PK3	33PS	2	0.9	33UP	33UPK3	33UPS	
54 9/16	1385	3	1.4	54P	54PK3	54PS	3	1.4	54UP	54UPK3	54UPS	
62 9/16	1590	3 1/2	1.6	63P	63PK3	N336EC	3 1/2	1.6	63UP	63UPK3	63UPS	
74 5/8	1895	4	1.8	74P	74PK3	N356EC	4	1.8	74UP	74UPK3	74UPS	
86 5/8	2200	5	2.3	86P	86PK3	N366EC	4 1/2	2.0	86UP	86UPK3	86UPS	
96 5/8	2454	5 1/2	2.5	96P	—	—	—	—	—	—	—	

¹ Height includes leveling bolt and cap. Stainless stationary post includes stainless leveling bolt.

² 96P should not be used on units less than 24" (610 mm) deep.

** Note: Special length posts are available, priced at next higher length plus a cutting charge. Post lengths to be specified as cut to a round number, ie: 74P cut to 69" (1753 mm)... This will result in an overall post height with adjustment of 69 3/8" (1762 mm) to 69 7/8" (1775 mm).

These posts come without leveling bolt assembly to accommodate stem casters.

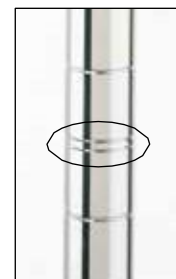

SiteSelect™ Posts are grooved at 1" (25 mm) increments and numbered at 2" (50 mm) increments. Posts are double-grooved every 8" (203 mm) for easy identification.

Super Erecta® EZ-ADD Shelf Units

Super Erecta® EZ-ADD Shelf



A wire shelf that is easily added or removed from a Metro wire shelving unit without dismantling the shelving unit. Patent pending one-piece polymer collar has a built-in bead that captures the groove in the 1" (25mm) diameter post. A stainless lock plate ensures a tight fit for the collar assembly and holds the shelf in position. EZ-ADD shelves have a load rating (evenly distributed) of 400lbs (181kg).

- › Add/remove an EZ-ADD shelf easily without dismantling the shelving unit.
- › Add more storage levels faster than conventional wire shelving.
- › Load Capacity per Shelf: 400lbs (181kg) evenly distributed.
- › Chrome and Metroseal Green finishes. Metroseal has a 12-year limited warranty against rust and corrosion.
- › Single packs: consist of the shelf, (4) EZ-ADD collars and (4) lock plates.
- › Retrofits easily to existing Metro wire shelving units.
- › NSF listed

Material Specifications and Usage Guidelines

- › Wire shelf: cold rolled steel.
- › Chrome: genuine nickel chrome with a protective lacquer exterior coat.
- › Metroseal Green: Corrosion-resistant Epoxy coating with built-in Microban® protection over a protective zinc substrate. Microban antimicrobial product protection continuously fights the growth of bacteria, mold, and mildew that cause stains and odors.
- › Collar: Nylon
- › Lock Plate: Type 304 stainless steel.
- › Continuous Temperature Usage: -20 to 120F (-29 to 49C).
- › EZ-ADD components are designed for use with Metro brand wire shelving.



EZ-ADD shelves increase storage and organization without dismantling the shelving unit.



Also Available in Metroseal Green

EZ-ADD Wire Shelves

- › EZ-ADD Shelves must be added within a unit having four posts.
- › Collars and lock plates are included with each shelf.

Cat. No Chrome	Cat. No Metroseal Green	Nominal Dimensions inch (W x L)	Nominal Dimensions mm (W x L)	Approx. Pkd. Wt. (lbs.)	Approx. Pkd. Wt. (kg)
EZA-1836NC	EZA-1836NK3	18x36	457 x 914	8.7	3.9
EZA-1848NC	EZA-1848NK3	18x48	457 x 1219	11.3	5.1
EZA-1860NC	EZA-1860NK3	18x60	457 x 1524	15.1	6.8
EZA-2436NC	EZA-2436NK3	24x36	610 x 914	11.8	5.4
EZA-2448NC	EZA-2448NK3	24x48	610 x 1219	15.3	6.9
EZA-2460NC	EZA-2460NK3	24x60	610 x 1524	18.8	8.5

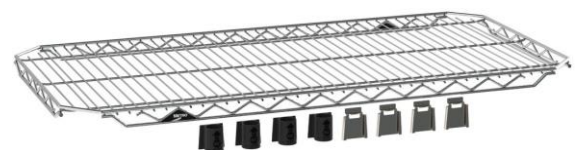

Actual Width = Nominal
Actual Length: Subtract 0.25" (6mm) from nominal length.

Super Erecta® NK3 Metroseal Wire Shelving

Super Erecta® NK3 Shelving

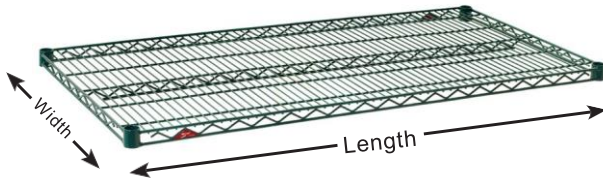

Metro's proprietary epoxy coating, Metroseal 3™ (NK3), contains Microban® antimicrobial product protection, which protects the epoxy coating from bacteria, mold, mildew and fungus that cause odours, stains and product degradation

Standard Interchangeable Shelves

- Part number includes 4/5 shelves, 4 posts and one bag of split sleeves per shelf

Width (mm)	Length (mm)	4 Tier Unit with 74" posts		5 Tier Unit with 74" posts	
		4 Shelf kit Model No.	Approx. Pkd. Wt. (kg)	5 Shelf kit Model No.	Approx. Pkd. Wt. (kg)
355	760	NK3.4T74.1430	19.3	NK3.5T74.1430	22.5
355	915	NK3.4T74.1436	20.9	NK3.5T74.1436	24.5
355	1065	NK3.4T74.1442	23.7	NK3.5T74.1442	28
355	1220	NK3.4T74.1448	25.3	NK3.5T74.1448	30
355	1525	NK3.4T74.1460	31.7	NK3.5T74.1460	38
355	1830	NK3.4T74.1472	37.8	NK3.5T74.1472	45
455	760	NK3.4T74.1830	21.3	NK3.5T74.1830	26.3
455	915	NK3.4T74.1836	24	NK3.5T74.1836	29.5
455	1065	NK3.4T74.1842	25.9	NK3.5T74.1842	31.8
455	1220	NK3.4T74.1848	28.6	NK3.5T74.1848	35.4
455	1370	NK3.4T74.1854	33.2	NK3.5T74.1854	40.5
455	1525	NK3.4T74.1860	37.2	NK3.5T74.1860	46.3
455	1830	NK3.4T74.1872	42.6	NK3.5T74.1872	53.1
535	915	NK3.4T74.2136	26.8	NK3.5T74.2136	33.1
535	1065	NK3.4T74.2142	29.5	NK3.5T74.2142	36.7
535	1220	NK3.4T74.2148	32.2	NK3.5T74.2148	39.9
535	1370	NK3.4T74.2154	35.5	NK3.5T74.2154	44.5
535	1525	NK3.4T74.2160	39.9	NK3.5T74.2160	49.4
535	1830	NK3.4T74.2172	44.5	NK3.5T74.2172	55.3
610	760	NK3.4T74.2430	25.9	NK3.5T74.2430	32.2
610	915	NK3.4T74.2436	29.5	NK3.5T74.2436	36.7
610	1065	NK3.4T74.2442	32.7	NK3.5T74.2442	40.4
610	1220	NK3.4T74.2448	35.8	NK3.5T74.2448	44.5
610	1370	NK3.4T74.2454	39.5	NK3.5T74.2454	49.8
610	1525	NK3.4T74.2460	44.5	NK3.5T74.2460	55.3
610	1830	NK3.4T74.2472	54.4	NK3.5T74.2472	67.6



Split Sleeve Locking System

SiteSelect Posts

Stationary post height includes leveling bolt for uneven floors

NOTE: Special length posts are available upon request. Consult your Metro representative.

Stationary

Height (mm)	Weight (kg)	Super Erecta Model No.
1385	1.4	54PK3
1890	1.8	74PK3
2200	2.3	86PK3



Mobile (For use with stem castors)

Height (mm)	Weight (kg)	Super Erecta Model No.
1570	1.6	63UPK3



Foot Plates

- Use to bolt units to the floor, or when a broader, more stable foot is desired. Foot plates also help to protect floors by distributing the point load of the shelving unit across a larger contact point
- Foot plates (completely tightened) add 3mm to the specified heights of each stationary post on the table
- Zinc Model no. **9993Z**
- Stainless Steel Model no. **9993S**



"S" Hook

- Used to add on shelving units with only two posts required. Order two per shelf level.
- Model no. **9995Z**



Super Erecta® – Shelving Accessories

Super Erecta® Conductive Plastic Split Sleeves

Required for Super Erecta® Shelving ESD applications.

Four sets of sleeves to a bag.

Cat. No. 9985-ESD



Replacement Plastic Split Sleeves

One bag required per shelf; 4 pairs per bag.

Cat. No. 9985



Aluminum Split Sleeves

Improved design is easier to install. For high temperature, over the road, or conductive applications. Zinc or stainless steel retainer rings available to secure shelf.

One bag required per shelf; 4 pairs per bag.

Aluminum Split Sleeves with Zinc Rings

Cat. No. 9986Z

Aluminum Split Sleeves with Stainless Rings

Cat. No. 9986S



Post Clamps

Joins units together for maximum strength.

Plated.

Cat. No. 9994Z



Foot Plates

Use to bolt units to the floor, or when a broader, more stable foot is desired. Replaces standard post leveling bolt.

Plated.

Cat. No. 9993Z

Stainless Steel.

Cat. No. 9993S



'S' Hooks

Use to eliminate two posts per adjacent unit. Two S-Hooks required per shelf.

Cat. No. 9995Z



Three-Sided Double Snake Frames

Provide additional support or access to floor with these sturdy square snake frames. Chrome finish.

Inch (W x L x H)	mm (W x L x H)	Approx. Pkd. Wt. lbs	Approx. Pkd. Wt. kg	Cat. No
18 x 24	457 x 610	43	2.3	SF31N3C
18 x 30	457 x 760	47	2.7	SF32N3C
18 x 36	457 x 914	52	2.7	SF33N3C
18 x 42	530 x 914	59	3.2	SF34N3C
24 x 24	610 x 914	65	3.5	SF35N3C
24 x 30	457 x 610	43	2.7	SF51N3C
24 x 42	457 x 760	47	3.2	SF52N3C
24 x 60	530 x 914	59	3.6	SF54N3C
24 x 72	610 x 914	65	4.1	SF55N3C
			4.5	SF56N3C
			5.0	SF57N3C

Storage Baskets

Generous-sized baskets attach in seconds to shelves.

Inch (W x L x H)	mm (W x L x H)	Approx. Pkd. Wt. lbs	Approx. Pkd. Wt. kg	Cat. No
13 1/2 x 5 x 7	345 x 127 x 180	8 1/2	4	H209C
17 1/2 x 7 1/2 x 5	440 x 190 x 127	7	3	H210C
17 1/2 x 7 1/2 x 10	440 x 190 x 255	11	5	H212C

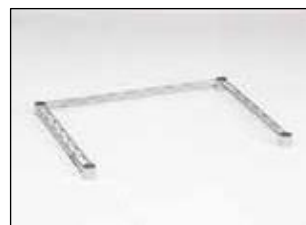

Three-sided Double Snake Frame



Large Storage Basket

Super Erecta® – Shelving Accessories

Shelf Dividers for Super Erecta® Shelves

Keep shelf contents orderly with these 8" (203 mm) high, pressure-fit dividers.

Shelf width inch	Shelf width mm	Approx. Pkd. Wt. lbs	Approx. Pkd. Wt. kg	Cat. No Plated	Cat. No Stainless
14	355	1.8	0.8	DD14C	DD14S
18	457	2.25	1.0	DD18C	DD18s
21	530	2.5	1.1	DD21C	DD21S
24	610	2.75	1.3	DD24C	DD24S

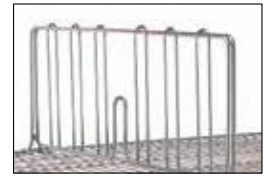

Shelf Divider for Super Erecta® Shelves

Shelf Ledges - Side and Back

For stationary or mobile installations, ledges prevent items from protruding or falling from shelves. 4" (100 mm) High Stackable Ledges.

Shelf width inch	Shelf width mm	Approx. Pkd. Wt. lbs	Approx. Pkd. Wt. kg	Cat. No Plated	Cat. No Stainless	Shelf width inch	Shelf width mm	Approx. Pkd. Wt. lbs	Approx. Pkd. Wt. kg	Cat. No Plated	Cat. No Stainless
14	355	0.83	0.36	L14N-4C	L14N-4S	14	355	0.58	0.25	L14N-1C	L14N-1S
18	457	1.5	0.68	L18N-4C	L18N-4S	18	457	0.75	0.33	L18N-1C	L18N-1S
21	530	1.75	0.71	L21N-4C	L21N-4S	21	530	0.75	0.33	L21N-1C	L21N-1S
24	610	2.0	0.9	L24N-4C	L24N-4S	24	610	1.0	0.45	L24N-1C	L24N-1S
30	760	2.25	1.03	L30N-4C	L30N-4S	30	760	2.0	0.9	L30N-1C	L30N-1S
36	914	2.75	1.25	L36N-4C	L36N-4S	36	914	2.5	1.13	L36N-1C	L36N-1S
42	1066	3.25	1.48	L42N-4C	L42N-4S	42	1066	2.75	1.25	L42N-1C	L42N-1S
48	1219	3.75	1.68	L48N-4C	L48N-4S	48	1219	3.5	1.58	L48N-1C	L48N-1S
54	1370	3.8	1.73	L54N-4C	L54N-4S	54	1370	4.4	1.65	L54N-1C	L54N-1S
60	1524	4.0	1.81	L60N-4C	L60N-4S	60	1524	3.75	1.68	L60N-1C	L60N-1S
72	1828	5.0	2.25	L72N-4C	L72N-4S	72	1828	4.0	1.81	L72N-1C	L72N-1S

Note: Actual ledge length is approximately 1" (25 mm) shorter than nominal shelf length/width.

Note: Actual ledge length is approximately 1" (25 mm) shorter than nominal shelf length/width.



4" (102 mm) Ledge

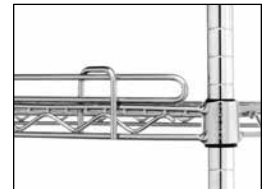

1" (25 mm) Ledge

Clear Label Holders

Clear plastic allows decorator colors to show through.

Holds most commercial 1 1/4" (32 mm) labels. Labels not included.

Label Size inch	Label Size mm	Fits Shelf Length inch	Fits Shelf Length mm	Cat. No
3 x 1/4	75 x 32	All	All	9990CL
13 x 1/4	330 x 32	18	457	9990CL1
19 x 1/4	480 x 32	24	610	9990CL2
25 x 1/4	635 x 32	30	760	9990CL30
31 x 1/4	725 x 32	36	914	9990CL3
43 x 1/4	1090 x 32	48	1219	9990CL4
55 x 1/4	1395 x 32	60	1520	9990CL5



Clear Label Holder

Reclaim Wasted Space

03

Metro Shelving
Super Adjustable™



Super Adjustable™ Shelving
Adjust and add shelves quickly and easily to reclaim wasted space.



Super Erecta

Easy 'no-tool' shelf adjustment

1" (25mm) spacing minimizes dead space

Efficient use of space allows more storage levels to be added.

Storage efficiency can increase by 25% or more



Super Adjustable
Super Erecta

Super Adjustable™ – Shelving Units & Accessories

Super Adjustable™ Wire Shelves

Packaging: Wire shelves are packaged 4 to a carton (shelves sold separately) except 60" (1524 mm) and 72" (1829 mm) lengths and 30" (760 mm) and 36" (914 mm) widths, which are packaged 2 to a carton (shelves sold separately).

Plastic sleeves and wedges are included with each shelf. Advantages include:

- **Adjustability:** Patented release lever means shelves can be quickly and easily adjusted at 1" (25 mm) increments along the entire length of the post.
- **Unique Shelf Design:** Super Adjustable offers the patented shelf release method for fast and easy shelf adjustment.
- **Open-wire Construction:** Minimizes dust accumulation and allows a free circulation of air and greater visibility.
- **Unique Post Design:** SiteSelect posts, with reoccurring double grooves provides a visual guide for positioning shelves.
- **Available in Type 304 stainless steel, durable chrome-plated and patented Metroseal 3 (corrosion resistant epoxy).**

Inch (W x L)	mm (W x L)	Approx. Pkd. Wt. lbs	Approx. Pkd. Wt. kg	Cat. No Chrome	Cat. No Metroseal 3 with Microban	Cat. No Stainless
14 x 24	355 x 610	6	2.7	A1424NC	A1424NK3	A1424NS
14 x 30	355 x 760	7	3.2	A1430NC	A1430NK3	A1430NS
14 x 36	355 x 914	8	3.6	A1436NC	A1436NK3	A1436NS
14 x 42	355 x 1066	9 1/2	4.3	A1442NC	A1442NK3	A1442NS
14 x 48	355 x 1219	10 1/2	4.7	A1448NC	A1448NK3	A1448NS
14 x 60	355 x 1524	17	6.3	A1460NC	A1460NK3	A1460NS
14 x 72	355 x 1829	7	7.7	A1472NC	A1472NK3	A1472NS
18 x 24	457 x 610	7	3.2	A1824NC	A1824NK3	A1824NS
18 x 30	457 x 760	8	3.6	A1830NC	A1830NK3	A1830NS
18 x 36	457 x 914	9 1/2	4.3	A1836NC	A1836NK3	A1836NS
18 x 42	457 x 1066	11	5	A1842NC	A1842NK3	A1842NS
18 x 48	457 x 1219	12	5.4	A1848NC	A1848NK3	A1848NK3
18 x 54	457 x 1370	14 1/2	6.6	A1854NC	A1854NK3	A1854NS
18 x 60	457 x 1524	17	7.7	A1860NC	A1860NK3	A1860NS
18 x 72	457 x 1829	20	9.1	A1872NC	A1872NK3	A1872NS
21 x 24	530 x 610	9	4.1	A2124NC	A2124NK3	A2124NS
21 x 30	530 x 760	11	5	A2130NC	A2130NK3	A2130NS
21 x 36	530 x 914	13	5.9	A2136NC	A2136NK3	A2136NS
21 x 42	530 x 1066	15	6.8	A2142NC	A2142NK3	A2142NS
21 x 48	530 x 1219	16	7.3	A2148NC	A2148NK3	A2148NS
21 x 54	530 x 1370	18	8.6	A2154NC	A2154NK3	A2154NS
21 x 60	9530 x 1524	21	9.5	A2160NC	A2160NK3	A2160NS
21 x 72	530 x 1829	26	11.8	A2172NC	A2172NK3	A2172NS
24 x 24	610 x 610	9	4.1	A2424NC	A2424NK3	A2424NS
24 x 30	610 x 760	11	5	A2430NC	A2430NK3	A2430NS
24 x 36	610 x 914	13	5.9	A2436NC	A2436NK3	A2436NS
24 x 42	610 x 1066	15	6.8	A2442NC	A2442NK3	A2442NS
24 x 48	610 x 1219	16	7.3	A2448NC	A2448NK3	A2448NS
24 x 54	610 x 1370	18	8.6	A2454NC	A2454NK3	A2454NS
24 x 60	610 x 1524	21	9.5	A2460NC	A2460NK3	A2460NS
24 x 72	610 x 1829	26	11.8	A2472NC	A2472NK3	A2472NS
30 x 36	760 x 914	15	6.8	A3036NC	-	A3036NS
30 x 48	760 x 1219	21	9.5	A3048NC	-	A3048NS
30 x 60	760 x 1524	26 1/2	11.8	A3060NC	-	A3060NS
30 x 72	760 x 1829	31	14	A3072NC	-	A3072NS
36 x 36	910 x 914	18	8.2	A3636NC	-	A3636NS
36 x 48	910 x 1219	23	10.4	A3648NC	-	A3648NS
36 x 60	910 x 1524	29	13.1	A3660NC	-	A3660NS
36 x 72	910 x 1829	34 1/2	15.4	A3672NC	-	SEC53C



SiteSelect™ Posts are grooved at 1" (25 mm) increments and numbered at 2" (50 mm) increments. Posts are double-grooved every 8" (203 mm) for easy identification.

Metro Fact:

Metroseal 3 is enhanced with built-in Microban® antimicrobial product protection, a Metro exclusive, which protects the Metroseal 3 coating from bacteria, mold, mildew and fungi that cause odors, stains and product degradation.

Shelves and posts are carton packed but sold separately.

SiteSelect™ Posts

Stationary Super Erecta® (works with Super Adjustable™) SiteSelect posts are fitted with adjustable leveling bolts to compensate for uneven surfaces. Mobile posts come without leveling bolt assembly to accommodate stem casters. Special length posts are available.⁴

Stationary						
Height ¹ inch	Height ¹ mm	Approx. Pkd. Wt. lbs	Approx. Pkd. Wt. kg	Cat. No Chrome	Cat. No Metroseal 3 with Microban	Cat. No Stainless ²
7 1/2	191	1/2	0.3	7P	-	-
14 1/2	370	1	0.5	13P	13PK3	13PS
27 1/2	699	1 3/4	0.75	27P	-	27PS
34 1/2	875	2	0.9	33P	33PK3	33PS
54 9/16	1385	3	1.4	54P	54PK3	54PS
62 9/16	1590	3 1/2	1.6	63P	63PK3	N336EC
74 7/8	1895	4	1.8	74P	74PK3	N356EC
86 3/8	2200	5	2.3	86P	86PK3	N366EC
96 3/8	2454	5 1/2	2.5	96P	-	-

Mobile					
Approx. Pkd. Wt. lbs	Approx. Pkd. Wt. kg	Cat. No Plates	Cat. No Metroseal 3 with Microban	Cat. No Stainless ²	
-	-	7UP	-	-	
1	0.5	13UP	13UPK3	13UPS	
1 3/4	0.75	27UP	-	27UPS	
2	0.9	33UP	33UPK3	33UPS	
3	1.4	54UP	54UPK3	54UPS	
3 1/2	1.6	63UP	63UPK3	63UPS	
4	1.8	74UP	74UPK3	74UPS	
4 1/2	2.0	86UP	86UPK3	86UPS	
-	-	-	-	-	

¹ Height includes leveling bolt and cap. ² Stainless stationary post includes stainless leveling bolt.

³ 96P should not be used on units less than 24" (610 mm) deep.

⁴ Note: Special length posts are available, priced at next higher length plus a cutting charge. Post lengths to be specified as cut to a round number, i.e. 74P cut to 69" (1753 mm)... This will result in an overall post height with adjustment of 69 3/8" (1762 mm) to 69 7/8" (1775 mm).

These posts come without leveling bolt assembly to accommodate stem casters.



Take confidence to the max.

MetroMax[®] All-Polymer Shelving System



Safely hold up to
900 kg.
per unit.



Metro Fact:

All MetroMax[®] Shelving comes standard with Microban[®] antimicrobial product protection built into the shelf mats to inhibit stain and odor causing bacterial, mildew, and mold growth.

Metro Shelving

MetroMax i®

04

RUST PROOF POLYMER & HYBRID POLYMER/WIRE SHELVING

MetroMax polymer systems provide a smooth surface that won't corrode or rust. The shelves also contain Microban® antimicrobial protection that keeps the shelves cleaner between cleanings. Shelving and carts within each series (as noted) feature dividers, ledges, enclosure panels, MetroMax slides and tote boxes in various combinations which can be removed and reconfigured to adapt to changes in supply, volume, and packaging.

MetroMax i® Storage System

The most revolutionary and advanced system of its kind in the marketplace today.

- › **Corrosion and Rust Proof** - MetroMax i® has a lifetime warranty against corrosion and rust.
- › **Versatile** - Shelves adjust at 1" (25 mm) increments along the height of the posts.
- › **Adaptable** - Accessories such as shelf dividers, stackable ledges, tray slides, label holders, and more, allow customization to your exact needs.
- › **Flexible** - Solid and open-grid shelf mats remove from shelf frame and interchange in seconds.
- › **Cleanable** - Mats lift off for cleaning. Open-grid mats fit easily into the dishwasher.
- › **Strong and Durable** - Reinforced polymers give MetroMax i® incredible strength - 800 lbs. (375 kg) per shelf up to 48" (1219 mm) length and 600 lbs. (275 kg) per shelf over 48" (1219 mm) long.

Shelves

Complete with frame, open-grid or solid shelf mat, and four wedge connectors.



inch (W x L x H)	mm (W x L x H)	Approx. Pkd. Wt. lbs	Approx. Pkd. Wt. kg	Cat. No Open Grid Shelf	Approx. Pkd. Wt. lbs	Approx. Pkd. Wt. kg	Cat. No Solid Shelf
18 x 24	457 x 610	10	4.5	MX1824G	11	4.8	MX1824F
18 x 30	457 x 760	11	5	MX1830G	13	5.6	MX1830F
18 x 36	457 x 914	12	5.4	MX1836G	14	6.4	MX1836F
18 x 42	457 x 1066	14	6.2	MX1842G	17	7.3	MX1842F
18 x 48	457 x 1219	16	7.3	MX1848G	18	8.2	MX1848F
18 x 54	457 x 1370	18	8.2	MX1854G	22	8.9	MX1854F
18 x 60	457 x 1524	20	9.1	MX1860G	23	9.8	MX1860F
18 x 72	457 x 1829	22.5	10.2	MX1872G	27.5	12.5	MX1872F
24 x 24	610 x 610	11	5	MX2424G	12	5.7	MX2424F
24 x 30	610 x 760	14	6.2	MX2430G	15	6.7	MX2430F
24 x 36	610 x 914	15	6.8	MX2436G	18	7.7	MX2436F
24 x 42	610 x 1066	17	7.6	MX2442G	21	8.8	MX2442F
24 x 48	610 x 1219	19	8.6	MX2448G	23	9.8	MX2448F
24 x 54	610 x 1370	21	9.5	MX2454G	25	10.8	MX2454F
24 x 60	610 x 1524	23	10.4	MX2460G	28	11.8	MX2460F
24 x 72	610 x 1829	26	11.8	MX2472G	31	14	MX2472F

Posts

Polymer construction. Adjustable at 1" (25 mm) increments. Stationary posts are fitted with adjustable leveling bolts to compensate for uneven surfaces.



Height inch	Height mm	Approx. Pkd. Wt. lbs	Approx. Pkd. Wt. kg	Cat. No Stationary	Cat. No Mobile
13	370	0.5	0.2	MX13P	MX13UP
33	875	1	0.45	MX33P	MX33UP
54	1370	1.5	0.7	MX54P	MX54UP
63	1585	2	0.9	MX63P	MX63UP
74	1890	2.25	1	MX74P	MX74UP
86	2195	2.5	1.2	MX86P	MX86UP



Post with Wedge Connector

Wedge Connector Bag of 4. Cat. No. MX9985

(Included with each shelf or shelf frame.)

MetroMax i® – Accessories

MetroMax i® Stem Casters

Use with MetroMax i® stem caster posts and shelves to create a mobile shelving unit to meet your specific needs.

Type	Wheel Tread	Load Rating lbs	Load Rating kg	Approx. Pkd. Wt. lbs	Approx. Pkd. Wt. kg	Cat. No
Stem/Swivel	Resilient	200	91	2 3/4	1.2	5MX
Stem/Brake	Resilient	200	91	3	1.4	5MBX
Stem/Rigid*	Resilient	200	91	3 3/4	1.7	5MRX
Stem/Swivel	Polyurethane	300	135	2 1/4	1.0	5MPX
Stem/Brake	Polyurethane	300	135	2 1/2	1.1	5MPBX
Stem/Rigid*	Polyurethane	300	135	2 1/4	1.0	5MPRX
Stem/Swivel	Resilient Donut	250	113	2 1/2	1.1	5MDXA
Stem/Brake	Resilient Donut	250	113	2 1/2	1.1	5MDBXA
Stem/Rigid*	Resilient Donut	250	113	2 1/2	1.1	5MDRXA



5MPX

MetroMax bumpers included.

*Note: Rigid casters are held in place by a connecting channel. When ordering, shelf width must be provided.

Polymer Casters

Innovative polymer stem casters offer corrosion resistance and enhanced durability.

- › All-polymer horn, stainless steel axle and hardware, 5" (127 mm) diameter polyurethane wheel, sleeve-style axle bearing and an optional toe-operated brake mechanism.
- › Load rating of 300 lbs. (135 kg) and a temperature range from -20° to 120°F (continuous).
- › Recommended for all medium-duty applications.

Type	Wheel Tread	Wheel Diameter inch	Wheel Diameter mm	Wheel/Tread Width inch	Wheel/Tread Width mm	Approx. Pkd. Wt. lbs	Approx. Pkd. Wt. kg	Cat. No	Cat. No Antimicrobial
Swivel	Polyurethane	5	127	1.25	32	2	0.9	5PCX	5PCXM
Brake	Polyurethane	5	127	1.25	32	2	0.9	5PCBX	5PCBXM
Rigid	Polyurethane	5	127	45393	32	2	0.9	5PCRX	—



5PCX

5PCBX

Note 1: Stem casters are shipped with donut bumpers at no extra charge.

Note 2: Rigid casters are held in place by a connecting channel. When ordering, shelf width must be provided.

Stainless Steel Cart-Washable Stem Casters

Type	Wheel Tread	Load Rating lbs	Load Rating kg	Approx. Pkd. Wt. lbs	Approx. Pkd. Wt. kg	Cat. No
Stem/Swivel	Polyurethane	300	135	2 1/8	1.0	5MPXGSA
Stem/Brake	Polyurethane	300	135	2 1/8	1.0	5MPBXGSA
Stem/Rigid*	Polyurethane	300	135	2 1/8	1.0	5MPRXGSA

MetroMax i® Redefining Space Management

Develop a custom storage installation by combining individual MetroMax i® units in a variety of combinations utilizing 'S' hooks and/or Intermediate 'S' hook kits. Join units end-to-end, back-to-back, or at right angles.

'S' Hook Kit

Add on shelving to existing units using two posts instead of four. Kit includes one 'S' hook and one corner collar plug. Two kits required per storage level when configuring units end-to-end. Cat. No. M9995.

Intermediate 'S' Hook Kit

Required when joining units at right angles with open corner and no post. Intermediate bracket and an 'S' Hook connect a shelf corner to the front beam of the adjoining shelf. Kit includes one intermediate bracket, two 'S' Hooks, and two corner collar plugs. See illustration below for quantity required per level. Cat. No. MX9996.



'S' Hook



Intermediate Bracket and 'S' Hook

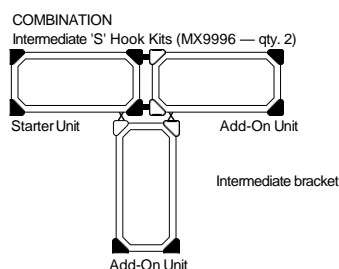
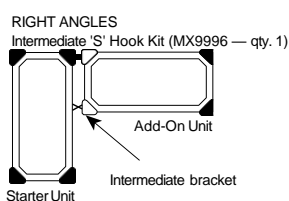
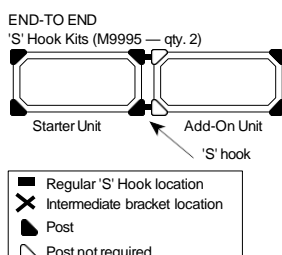

MetroMax i® – Accessories

Enclosure Panels

An efficient way of enclosing the sides and back of all shelves in a unit. Durable gray epoxy finish.

Encloses								
inch (W x H)	mm (W x H)	Post Height inch	Post Height mm	Shelf Width inch	Shelf Width mm	Approx. Pkd. Wt. lbs	Approx. Pkd. Wt. kg	Cat. No
12 3/8 x 51 1/4	315x1300	54	1370	18	457	6	2.7	MEP35E
12 3/8 x 59 1/4	315x1505	63	1600	18	457	6 3/4	3.0	MEP36E
12 3/8 x 71 1/4	315x1810	74	1880	18	457	8 1/2	3.8	MEP37E
18 3/8 x 51 1/4	467x1300	54	1370	24	610	8 3/4	3.9	MEP55E
18 3/8 x 59 1/4	467x1505	63	1600	24	610	10	4.5	MEP56E
18 3/8 x 71 1/4	467x1810	74	1800	24	610	11 1/2	5.1	MEP57E

Panels Required to Enclose Ends:

18" (457mm) Shelf Width			24" (610mm) Shelf Width		
54" (1370mm) Post	63" (1600 mm) Post	74" (1880 mm) Post	54" (1370 mm) Post	63" (1600 mm) Post	74" (1880 mm) Post
(2) MEP35E	(2) MEP36E	(2) MEP37E	(2) MEP55E	MEP56E	(2) MEP57E



MetroMax i® Mobile System with Enclosure Panels

Panels Required to Enclose Back:

Post Height	Cart Length (Shelf Length)						
	30" (760 mm)	36" (914 mm)	42" (1066 mm)	48" (1219 mm)	54" (1370 mm)	60" (1524 mm)	72" (1825 mm)
54" (1370mm)	(2) MEP35E	(1) MEP35E (1) MEP55E	(2) MEP55E	(1) MEP55E (2) MEP35E	(1) MEP35E (2) MEP55E	(3) MEP55E	(1) MEP35E (3) MEP55E
63" (1600mm)	(2) MEP36E	(1) MEP36E (1) MEP56E	(2) MEP56E	(2) MEP36E (1) MEP56E	(1) MEP36E (2) MEP56E	(3) MEP56E	(1) MEP36E (3) MEP56E
74" (1880mm)	(2) MEP37E	(1) MEP37E (1) MEP57E	(2) MEP57E	(2) MEP37E (1) MEP57E	(1) MEP37E (2) MEP57E	(3) MEP57E	(1) MEP37E (3) MEP57E

Stackable Shelf Ledges

Prevent items from falling or protruding from shelves. 2" (51 mm) ledges snap on, and can be stacked for additional height.

Length inch	Length mm	Type	Approx. Pkd. Wt. lbs	Approx. Pkd. Wt. kg	Cat. No 2" (51 mm) Ledge
18	457	Side	1 1/2	0.2	MXLS18-2S
24	610	Side	1 1/2	0.2	MXLS24-2S
24	610	Back	1 1/2	0.2	MQL24-2S
30	760	Back	3 3/4	0.3	MQL30-2S
36	914	Back	1	0.45	MQL36-2S
42	1066	Back	1 1/4	0.5	MQL42-2S
48	1219	Back	1 1/4	0.5	MQL48-2S
54	1370	Back	1 1/2	0.7	MQL54-2S
60	1524	Back	1 3/4	0.8	MQL60-2S
72	1825	Back	2	0.9	MQL72-2S



Stackable Shelf Ledges

Shelf Dividers

The easy way to organize any shelf. 8" high (203 mm) dividers snap into place, and can be repositioned quickly and easily.

Shelf width inch	Shelf width mm	Approx. Pkd. Wt. lbs	Approx. Pkd. Wt. kg	Cat. No
18	457	1 1/4	.5	MXD18-8
24	610	1 3/4	.8	MXD24-8

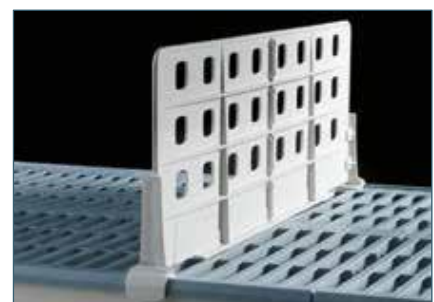

Shelf Divider

Metro Shelving

Solid Shelving

05

Setting the standard for solid shelving.

Perfect for applications involving spillage. Provides barrier between floor and bottom shelf contents to deter contamination.

- › Shelf design features a 1/8" (3.2 mm) raised 'ship's edge' on all four sides to contain spills.
- › Louvered/embossed shelf allows air circulation.
- › Available in several styles and materials for a variety of applications. Shelves are constructed with 18-gauge stainless steel (Type 304) or galvanized materials.



- › Galvanized shelves with uncoated cast corners are ideal for applications requiring a solid shelving or work surface and minimum resistance to corrosion. Available in flat solid, and louvered/embossed styles.
- › Standard Stainless Steel solid shelves (Type 304) with epoxy-coated cast corners address the majority of applications for solid, corrosion resistant shelves or work surfaces. Available in flat solid, and louvered/embossed styles.
- › Premium Autoclave/Cart Washable Stainless Steel solid shelves (Type 304) feature an all-stainless construction to withstand high temperature, corrosive applications. Available in flat solid style.

CaseVue™ Laboratory Carts

SiteSelect Posts for Super Erecta® Solid Shelving

Stationary posts are fitted with adjustable leveling bolts to compensate for uneven surfaces. Mobile posts come without leveling bolt to accommodate stem casters.**

Metro Tip:

Use Metro Flat Solid Shelving at the bottom of a storage unit to maintain cleanliness by providing a barrier between floor and shelf contents above.

Height inch	Height mm	Approx. Pkd. Wt. lbs	Approx. Pkd. Wt. kg	Cat. No Chrome Stationary	Cat. No Chrome Mobile	Cat. No Stainless Stationary	Cat. No Stainless Mobile
7 1/2	191		0.3	7P	7UP	—	—
14 1/2	370	1	05	13P	13UP	13PS	13UPS
27 1/2	699	1 3/4	0.75	27P	27UP	27PS	27UPS
34 1/2	875	2	0.9	33P	33UP	33PS	33UPS
54 1/8	1385	3	1.4	54P	54UP	54PS	54UPS
62 1/8	1590	3 1/2	1.6	63P	63UP	63PS	63UPS
74 1/8	1895	4	1.8	74P	74UP	74PS	74UPS
86 1/8	2200	5	2.3	86P	86UP	86PS	86UPS

* Height includes leveling bolt and cap.

** Note: Special length posts are available.

Post lengths to be specified as cut to a round number, ie 74P cut to 69" (1753 mm)... This will result in an overall post height with adjustment of 6933" (1762 mm) to 6978" (1775 mm).



SiteSelect™ Posts are grooved at 1" (25 mm) increments and numbered at 2" (50 mm) increments. Posts are double-grooved every 8" (203 mm) for easy identification.

Super Erecta® Solid Shelving

Shelves are priced and sold individually. For standard packaging, the number of shelves per box varies by size. Galvanized solid shelving has uncoated, aluminum cast corners. Standard Stainless Steel solid shelving has black powder-coated corners. Autoclavable/Cart-Washable Stainless Steel solid shelving has stainless steel corners.

inch (W x L)	mm (W x L)	Approx. Pkd. Wt. lbs	Approx. Pkd. Wt. kg	Galvanized		Standard Stainless Steel	
				Cat. No Flat	Cat. No Louvered/Embossed	Cat. No Flat	Cat. No Louvered/Embossed
14 x 24	355 x 610	10	4.5	1424FG	1424LG	1424FS	1424LS
14 x 30	355 x 760	12	5.4	1430FG	1430LG	1430FS	1430LS
14 x 36	355 x 914	14	6.4	1436FG	1436LG	1436FS	1436LS
14 x 42	355 x 1066	15	6.8	1442FG	1442LG	1442FS	1442LS
14 x 48	355 x 1219	17	7.7	1448FG	1448LG	1448FS	1448LS
14 x 60	355 x 1524	22	9.9	1460FG	1460LG	1460FS	1460LS
18 x 24	457 x 610	11	5	1824FG	1824LG	1824FS	1824LS
18 x 30	457 x 760	14	6.4	1830FG	1830LG	1830FS	1830LS
18 x 36	457 x 914	16	7.3	1836FG	1836LG	1836FS	1836LS
18 x 42	457 x 1066	18	8.2	1842FG	1842LG	1842FS	1842LS
18 x 48	457 x 1219	20	9.1	1848FG	1848LG	1848FS	1848LS
18 x 60	457 x 1524	24	10.9	1860FG	1860LG	1860FS	1860LS
21 x 24	530 x 610	13	5.9	2124FG	2124LG	2124FS	2124LS
21 x 30	530 x 760	15	6.8	2130FG	2130LG	2130FS	2130LS
21 x 36	530 x 914	18	8.2	2136FG	2136LG	2136FS	2136LS
21 x 42	530 x 1066	21	9.5	2142FG	2142LG	2142FS	2142LS
21 x 48	530 x 1219	23	10.4	2148FG	2148LG	2148FS	2148LS
21 x 60	530 x 1524	26	11.8	2160FG	2160LG	2160FS	2160LS
24 x 24	610 x 610	15	6.8	2424FG	2424LG	2424FS	2424LS
24 x 30	610 x 760	17	7.7	2430FG	2430LG	2430FS	2430LS
24 x 36	610 x 914	19	8.6	2436FG	2436LG	2436FS	2436LS
24 x 42	610 x 1066	21	9.5	2442FG	2442LG	2442FS	2442LS
24 x 48	610 x 1219	24	10.9	2448FG	2448LG	2448FS	2448LS
24 x 60	610 x 1524	31	14	2460FG	2460LG	2460FS	2460LS



Counter Unit

Autoclavable/Cart-Washable Solid Stainless Shelving

All-stainless construction can be used for autoclave and cart washing applications. Combine shelves with stainless swedged posts and aluminum sleeves with stainless rings for best results.

inch (W x L x H)	mm (W x L x H)	Approx. Pkd. Wt. lbs	Approx. Pkd. Wt. kg	Cat. No Autoclavable Stainless
14 x 24	355 x 610	10	4.5	1424NFS
14 x 30	355 x 760	12	5.4	1430NFS
14 x 36	355 x 914	14	6.4	1436NFS
14 x 42	355 x 1066	15	6.8	1442NFS
14 x 48	355 x 1219	17	7.7	1448NFS
14 x 60	355 x 1524	22	9.9	1460NFS
18 x 24	457 x 610	11	5.0	1824NFS
18 x 30	457 x 760	14	6.4	1830NFS
18 x 36	457 x 914	16	7.3	1836NFS
18 x 42	457 x 1066	18	8.2	1842NFS
18 x 48	457 x 1219	20	9.1	1848NFS
18 x 60	457 x 1524	24	10.9	1860NFS
21 x 24	530 x 610	13	5.9	2124NFS
21 x 30	530 x 760	15	6.8	2130NFS
21 x 36	530 x 914	18	8.2	2136NFS
21 x 42	530 x 1066	21	9.5	2142NFS
21 x 48	530 x 1219	23	10.4	2148NFS
21 x 60	530 x 1524	26	11.8	2160NFS
24 x 24	610 x 610	15	6.8	2424NFS
24 x 30	610 x 760	17	7.7	2430NFS
24 x 36	610 x 914	19	8.6	2436NFS
24 x 42	610 x 1066	21	9.5	2442NFS
24 x 48	610 x 1219	24	10.9	2448NFS
24 x 60	610 x 1524	31	14.0	2460NFS

Special Posts for Counter Units

	Unit Height inch	Unit Height mm	Post Height inch*	Post Height mm*	Approx. Pkd. Wt. lbs	Approx. Pkd. Wt. kg	Cat. No Plated	Cat. No Stainless
Upper Front Posts	63	1600	28 3/8	727	1 1/2	0.7	27PF	27PFS
	74	1880	40 3/8	1032	2	0.9	39PF	39PFS
Lower Front Posts	All	Heights	34 1/2	877	2	0.9	33PM	33PMS

*Height includes leveling bolt and cap.

Super Erecta® Counter Units

To create a counter unit, select the following components:

- 2 each - 14" (355 mm) deep upper shelves, listed above
- 2 each - 24" (610 mm) deep lower shelves, listed above
- 2 each - upper front posts, listed below
- 2 each - lower front posts, listed below
- 2 each - 63" (1600 mm) or 74" (1880 mm) high back posts.

Metro Tip:

Order aluminum split sleeves with stainless C-rings for corrosive, high-temperature, autoclave or cart wash applications. (Cat. No. 9986S, one bag required per shelf).

Solid Shelving

A. Site Select Posts For Stationary Shelving Applications

Combine required shelf sizes from previous page with stainless posts (4 required), below. Stainless posts are fitted with adjustable stainless steel leveling bolts to compensate for uneven surfaces.

Height inch*	Height mm*	Approx. Pkd. Wt. lbs	Approx. Pkd. Wt. kg	Cat. No. Stainless
14 1/2	370	1	0.5	13PS
27 1/2	700	1.75	0.75	27PS
34 1/2	875	2	0.9	33PS
54 9/16	1385	3	1.4	54PS
62 9/16	1590	3.5	1.6	N336EC
74 5/8	1895	4	1.8	N356EC
86 5/8	2200	5	2.3	N366EC

*Height includes leveling bolt and cap.



SiteSelect™ Posts are grooved at 1" (25 mm) increments and numbered at 2" (50 mm) increments. Posts are double-grooved every 8" (203 mm) for easy identification.

B. Site Select Posts For Mobile Applications

Combine required shelf sizes from previous page with stainless mobile posts (4), below. Mobile posts accept a wide range of Metro stem casters.

Height inch	Height mm	Approx. Pkd. Wt. lbs	Approx. Pkd. Wt. kg	Cat. No. Stainless
27 1/2	699	1 1/4	0.75	27UPS
33 7/8	861	2	0.9	33UPS
54	1370	3	1.4	54UPS
62	1575	3 1/2	1.6	63UPS
74	1880	4	1.8	74UPS
86	2185	4.5	2.0	86UPS

These posts come without leveling bolt assembly to accommodate stem casters.

C. Site Select Posts For Cart Wash (Mobile) Applications

Combine required shelf sizes with stainless swedged posts (4), below. Stainless steel cart washable casters are required for cart wash applications. Refer to chart below for recommended caster series.

Swedged Posts

Description	Dimensions inch	Dimensions mm	Cat. No.
Stem Caster Post	33	875	33UPS-SW
Stem Caster Post	54	1370	54UPS-SW
Stem Caster Post	63	1600	63UPS-SW

Stainless Steel Cart-Washable Stem Casters

Stem casters are shipped with donut bumpers.

Wheel Diameter inch	Wheel Diameter mm	Face inch	Face mm	Load Rating lbs	Load Rating kg	Type	Wheel Tread	Approx. Pkd. Wt. lbs	Approx. Pkd. Wt. kg	Cat. No.
5	127	1 1/4	32	150	68	Swivel	High Modulus	2 1/2	1.1	5MDGSA
5	127	1 1/4	32	150	68	Brake	High Modulus Donut	2 5/8	1.17	5MDBGSA
5	127	1 1/4	32	150	68	Rigid	High Modulus Donut	2 3/8	1.08	5MDRGSA
5	127	1 1/4	32	300	135	Swivel	Polyurethane	2 1/8	0.94	5MPGSA
5	127	1 1/4	32	300	135	Brake	Polyurethane	2 1/4	1	5MPBGSA
5	127	1 1/4	32	300	135	Rigid	Polyurethane	2	0.9	5MPRGSA

Note 1: Load Height 6 3/32" ± 1/16" (155 ± 1.5mm).

Note 2: All casters are grease sealed with zerk fittings in swivel and axle.

Note 3: Brakes are foot-operated.



5MDGSA

D. For Autoclave (Mobile) Applications

Combine required shelf sizes from previous page with stainless swedged posts (4 required), above. Aluminum split sleeves (Cat. No. 9986S) must be used for autoclave applications. High temperature stem casters must be selected from chart below.

Aluminum Split Sleeves

Improved design is easier to install. For high temperature, over the road, or conductive applications. Stainless steel retainer rings included. One bag required per shelf; 4 pairs per bag.



9986S

	Cat. No.
Aluminum Split Sleeves with Stainless Rings	9986S

High-temperature Autoclave Stem Casters

Type	Wheel Tread	Load Rating	Cat. No.
Swivel	Hi-temp Phenolic	300	5MHTP
Brake	Hi-temp Phenolic	300	5MHTPB
Swivel	Hi-temp Nylon	300	5MHTN
Brake	Hi-temp Nylon	300	5MHTNB

Note: Casters are temperature rated for up to 300°F (149°C)



5MHTP



5MHTPB



5MHTN



5MHTNB

Autoclavable Racks/Carts

Autoclavable Cage Racks

- › Preconfigured, autoclavable cage racks available in two footprints - 18x60 (457x1524 mm) and 24x60 (610x1524 mm).
- › Units are 69" (1753 mm) high, including casters. Casters must be ordered separately.
- › Carts come standard with swaged posts and aluminum split sleeves.

Dimensions inch	Dimensions mm	Approx. Pkd. Wt. lbs	Approx. Pkd. Wt. kg	Description	Cat. No.
18 x 60 x 69	457 x 1524 x 1753	136	61.7	5-shelf, 18" (457 mm) wide cage rack	LC5S2460
24 x 60 x 69	610 x 1524 x 1753	166	75.3	5-shelf, 24" (610 mm) wide cage rack	LC5S2460



LC5S2460 (casters sold separately)

Autoclave Cage Rack Covers

Dimensions inch*	Dimensions mm*	Approx. Pkd. Wt. lbs	Approx. Pkd. Wt. kg	Description	Cat. No.
20 x 62 x 61.5	508 x 1575 x 1562	6.0	2.7	Autoclavable cart cover for 18" (457 mm) wide Cage Rack	LC1860AC
26 x 62 x 61.5	660 x 1575 x 1562	7.0	3.2	Autoclavable cart cover for 24" (610 mm) wide cage rack	LC2460AC

Note: Autoclave cart covers are rated for approximately 70 cycles per cover.



54UPS-SW with autoclave cart cover (casters sold separately)

Autoclavable Lab Carts

- › Preconfigured, autoclavable Lab carts are available in two footprints - 18x24 (457x610 mm) and 24x36 (610x914 mm).
- › Choose between 2- and 3-shelf models
- › Units are 39" (991 mm) high, including casters. Casters must be ordered separately.
- › Carts come standard with swaged posts and aluminum split sleeves.

Dimensions inch*	Dimensions mm*	Approx. Pkd. Wt. lbs	Approx. Pkd. Wt. kg	Description	Cat. No.
18x24x39	457x610x991	25.0	11.3	2-shelf, 18" (457mm) wide Lab cart	LC2S1824
18x24x39	457x610x991	37.5	17.0	3-shelf, 18" (457mm) wide Lab cart	LC3S1824
24x36x39	610x914x991	46.5	21.1	2-shelf, 24" (610mm) wide Lab cart	LC2S2436
24x36x39	610x914x991	65.5	29.7	3-shelf, 24" (610mm) wide Lab cart	LC3S2436

Note: Autoclave cart covers are rated for approximately 70 cycles per cover.



LC2S1824 (casters sold separately)

Autoclave Lab Cart Covers

Dimensions inch*	Dimensions mm*	Approx. Pkd. Wt. lbs	Approx. Pkd. Wt. kg	Description	Cat. No.
20x26x33.5	508x660x851	3	1.4	Autoclavable cart cover for 18" (457 mm) wide Cage Rack	LC1824AC
26x38x33.5	660x965x851	3.5	1.6	Autoclavable cart cover for 24" (610 mm) wide cage rack	LC2436AC

Note: Autoclave cart covers are rated for approximately 70 cycles per cover.

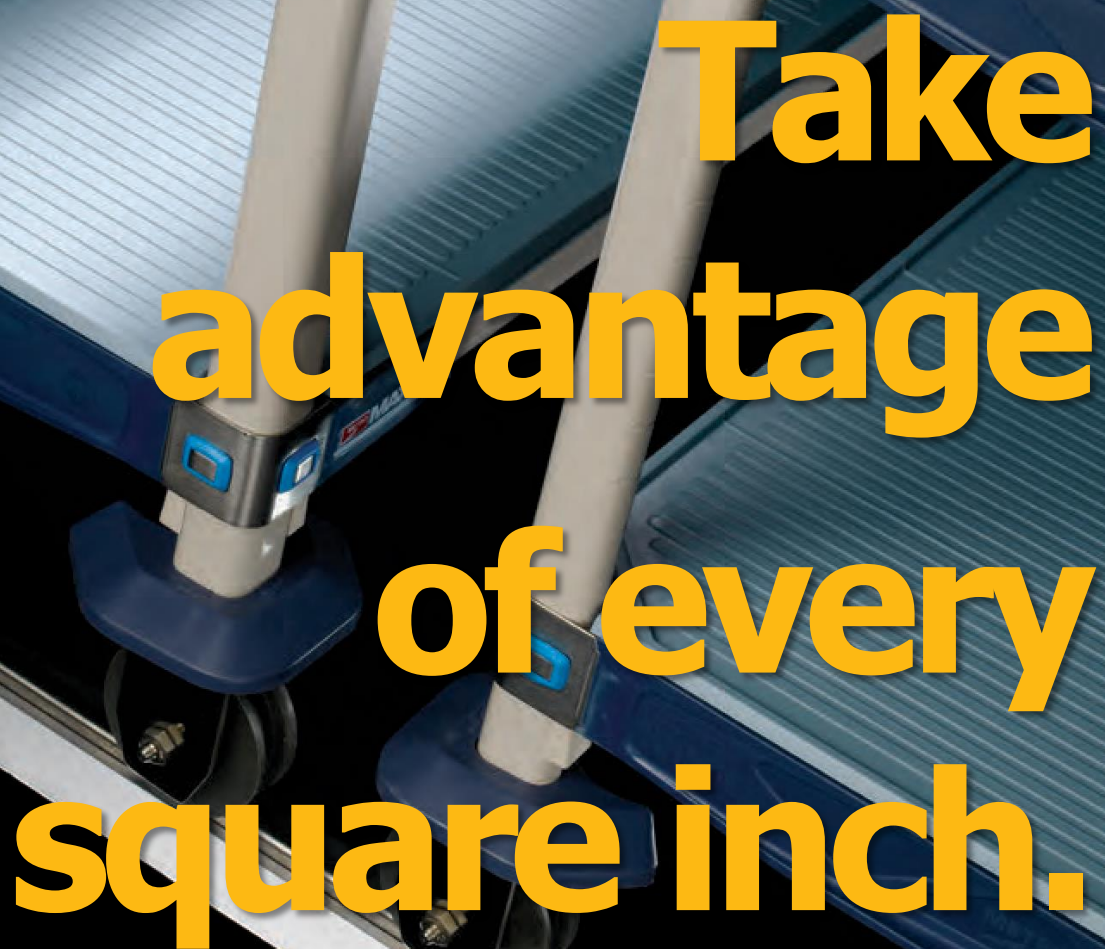

**Take
advantage
of every
square inch.**

More Space



More Production



More Turnover



Metro Shelving

Space Optimization

06

You're on the Right Track with Top-Track™

Metro's Top-Track and quikTRAK shelving solutions can optimize virtually any facilities' storage management. These systems expand storage capacity by up to 50%, offering weight capacities of 400-900 kg per mobile unit, and freeing up more space for more production activities.

Maximize Your Facility's Productivity with Top-Track and qwikTRAK: Giving You More Space for More Production

Top-Track and qwikTRAK systems are engineered to provide clients with more than just efficient shelving solutions, these systems give you the right tools to **save on space while also increasing your production potential**. This approach not only maximizes your storage capacity but also improves cost efficiency over time, reducing the need for facility expansion and allowing you to focus on what matters most: producing more. *Let's see how:*

Versatile: These systems come in various sizes, styles, and finishes to fit any environment, with corrosion-proof options for wet or corrosive conditions and smooth surfaces for sterile product storage.

■ Super Erecta®

Dry environment:

- › Kits with chrome posts for use with Chrome plated wire, Metro BRITE finish wire, Galvanized Solid shelving.

All environments:

- › Kits with Stainless Steel posts for use with Type 304 stainless steel wire or solid shelving.
- › Kits with Metroseal 3 coated posts for use with Metroseal 3 wire shelving & Super Erecta Pro with removable plastic shelf mats.

■ MetroMax - For use in all environments:

- › MetroMax i: (heavier duty polymer shelving with stainless corners) most commonly used with polymer posts.
- › MetroMax 4: all-polymer shelving; most commonly used with polymer posts.
- › MetroMax Q: (hybrid polymer and wire shelving) most commonly used with epoxy coated steel posts.

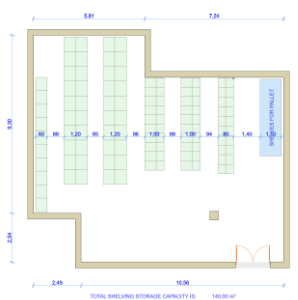

This traditional storage facility offered only 140m² of rack storage capacity.

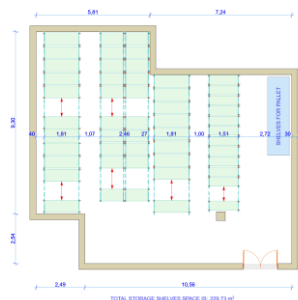

The use of Top-Track increased the potential shelving storage space to 229.73m², a 64% increase.

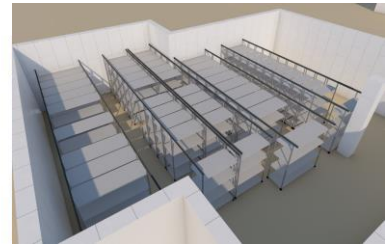

VIDEO:
bit.ly/4eb8TBj

This site was able to reduce the size of their storage space from 140m² to 54m² with equal storage capacity.

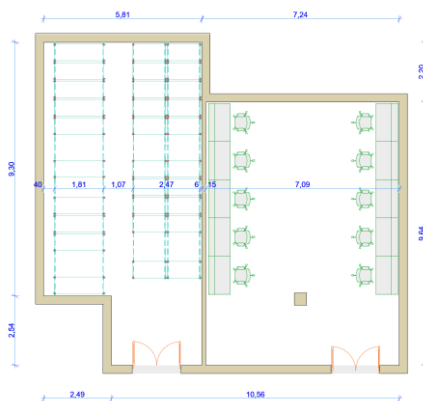

70m² of space were allocated to the development of a **NEW** production area.



How much profit could your facility generate over a twelve-month period with these new 70 square meters of space? The benefits of strategically implementing Top-Track or qwikTRAK can be validated with an economic analysis based on your specific space and production needs, under the full discretion of an NDA, if required.

qwikTRAK® High-Density Storage



Choose the shelving type based on the application.

Both single- and double-deep systems can be used with Metro wire shelving (Super Erecta® or Super Adjustable™ Super Erecta®) and polymer shelving system (MetroMax i®).



qwikTRAK key facts

The aluminum and stainless steel floor tracks provide a smooth, gliding surface for mobile units.

- › **Maximizes Storage Capacity:** qwikTRAK increases storage capacity by 50% by positioning mobile units between stationary units, eliminating the need for facility expansion.
- › **Ideal for Rough or Choppy Floors:** Floor tracks provide a smooth, level surface for mobile units, compensating for rough or uneven floors.
- › **Accessible and Ergonomic:** The low-profile guiding track and easy-to-move mobile units ensure safe and easy access to all stored products, even under heavy loads.
- › **Easy to Lay Out and Assemble:** End, intermediate, or mobile kits can be quickly assembled with various Metro shelving methods, with the guiding track easily positioned and anchored.
- › **Strong and Durable:** qwikTRAK units can hold up to 2,000 lbs (900 kg) per unit, with MetroMax units supporting up to 1,200 lbs (545 kg), ensuring robust and reliable storage.

THE SECRET TO
HIGH-DENSITY
STORAGE IS THE
ACTIVE AISLE
CONCEPT.

Double-Deep Configurations can be created where two systems are joined together to increase the overall depth of the storage system for even greater storage capacity.

- ✓ **Perfect for heavy loads.**
- ✓ **Smooth Gliding – Tracks protect floors from wear.**
- ✓ **Floor tracks compensate for rough floors.**
- ✓ **Aluminum & stainless track construction.**

Top-Track® High-Density Storage



Choose the shelving type based on your application.

Top-Track (single deep) can be used with Metro wire shelving (Super Erecta® or Super Adjustable™ Super Erecta®) and polymer shelving system (MetroMax i®).



Double-Deep configurations can be created when two systems are joined together to increase the overall depth of the storage system for even greater storage capacity. Double-Deep Top-Track is only available for Super Erecta® and Super Adjustable™ Super Erecta® style shelving.



TRADITIONAL STORAGE USES UP TO 20' OF SPACE



HIGH DENSITY STORAGE... THE SMART WAY TO PUT SPACE TO WORK.

Top-Track key facts

The guide track is positioned above the shelving system.

- › **Maximizes Storage Capacity:** Top-Track increases storage capacity by up to 40% by fitting more units in a defined space and providing full access to each unit.
- › **Easy Access:** The overhead track system allows access aisles to open between any two units, facilitating easy access for employees and utility carts.
- › **Cost-Saving Performance:** Efficient space utilization reduces the need for additional square footage in new facilities and eliminates expansion costs in growing operations.
- › **Uniquely Interchangeable:** Steel posts improve system rigidity for higher weight applications, while polymer posts can offer rust-proof performance.
- › **Clean Design:** Overhead guide tracks and removable polymer mats enable easy cleaning, while Microban protection stops bacteria, mold, mildew, and fungus growth.
- › **Increased Productivity:** By reducing storage space requirements, Top-Track frees up more productive space.

- Floors are easy to clean.
- Easy Access – Roll carts in & out of the aisles.
- Ideal for uneven floor surfaces.
- All-polymer options available.

Easy to Access. Hard to Steal.

Protect Valuables.

Keep sensitive items from
loss or pilferage.

Visible, yet Safe.

Ready View of Contents: Heavy-gauge
open wire construction keeps contents
visible at all times, making it easy to
check inventory.

07

Metro Shelving Security Shelving

Keep sensitive items safe from loss or pilferage with Metro's Security Shelving options. Heavy-gauge open wire construction keeps contents visible at all times, making it easy to check inventory. Each door opens 270 degrees and can be secured along the sides of the unit. Choose from stationary and mobile options.



SEC56EC (Super Erecta®
Mobile Security Shelving Unit,
Chrome)



**Keep'em
out!**

Security Shelving

Super Erecta® Shelf Stationary Security - 66 13/16" (1695 mm) high

Intermediate shelves are not included with base models and must be ordered separately.

Width inch	Width mm	Length inch	Length mm	Fits Shelf inch	Fits Shelf mm	Approx. Pkd. Wt. lbs	Approx. Pkd. Wt. kg	Cat. No Chrome	MICROBAN® Cat. No. Metroseal 3 with Microban	Cat. No Stainless Steel
21 1/2	546	38.5	980	18x36	457x914	138	63	SEC33C	SEC33K3	SEC33S
21 1/2	546	50.5	1295	18x48	457x1219	157	71	SEC35C	SEC35K3	SEC35S
27 1/4	692	38.5	980	24x36	610x914	154	70	SEC53C	SEC53K3	SEC53S
27 1/4	692	50.5	1295	24x48	610x1219	174	79	SEC55C	SEC55K3	SEC55S
27 1/4	692	62.5	1587	24x60	610x1524	195	89	SEC56C	SEC56K3	SEC56S
33 1/2	851	38.5	980	30x36	760x914	167	76	SEC63C	-	SEC63S
33 1/2	851	50.5	1295	30x48	760x1219	193	88	SEC65C	-	SEC65S
33 1/2	851	62.5	1587	30x60	760x1524	215	98	SEC66C	-	SEC66S



Standard-Duty Mobile Models — Stainless Steel

Intermediate shelves (see below) and casters must be ordered separately.

Description	Width inch	Width mm	Actual Length inch	Actual Length mm	Height inch	Height mm	Fits Shelf inch	Fits Shelf mm	Approx. Pkd. Wt. lbs	Approx. Pkd. Wt. kg	Cat. No Chrome	MICROBAN® Cat. No. Metroseal 3 with Microban	Cat. No Stainless Steel
Standard Duty	21 1/2	546	40.75	1035	62	1575	18x36	457x914	138	63	SEC33EC	SEC33EK3	SEC33S-SD
Standard Duty	21 1/2	546	52.75	1340	62	1575	18x48	457x1219	157	71	SEC35EC	SEC35EK3	SEC35S-SD
Standard Duty	27 1/4	692	40.75	1035	62	1575	24x36	610x914	154	70	SEC53EC	SEC53EK3	SEC53S-SD
Standard Duty	27 1/4	692	52.75	1340	62	1575	24x48	610x1219	174	79	SEC55EC	SEC55EK3	SEC55S-SD
Standard Duty	27 1/4	692	65	1651	62	1575	24x60	610x1524	195	89	SEC56EC	SEC56EK3	SEC56S-SD
Standard Duty	33 1/2	851	40.75	1035	62	1575	30x36	760x914	167	76	SEC63EC	-	SEC63S-SD
Standard Duty	33 1/2	851	52.75	1340	62	1575	30x48	760x1219	193	88	SEC65EC	-	SEC65S-SD
Standard Duty	33 1/2	851	65	1651	62	1575	30x60	760x1524	215	98	SEC66EC	-	SEC66S-SD

NOTE: Given height is for unit without casters. For approximate overall unit height add chosen caster diameter plus 1" (25 mm).

NOTE: Large casters can create a tipping hazard. On security units using 18" (457 mm) deep shelving, do not use casters larger than 5" (127 mm) in diameter.

Heavy-Duty Models — Stainless Steel

Intermediate shelves must be ordered separately (see below). Heavy-duty stainless steel models include staked posts for use with standard Metro dollies. Dolly bases and plate casters must be ordered separately.

Description	Width inch	Width mm	Actual Length inch	Actual Length mm	Height inch	Height mm	Fits Shelf inch	Fits Shelf mm	Approx. Pkd. Wt. lbs	Approx. Pkd. Wt. kg	Cat. No
Heavy Duty	28 1/16	713	38 1/2	980	62	1575	24x36	610x914	154	70	SEC53S-HD
Heavy Duty	28 1/16	713	50 1/2	1285	62	1575	24x48	610x1219	174	79	SEC55S-HD
Heavy Duty	28 1/16	713	63 1/8	1600	62	1575	24x60	610x1524	195	89	SEC56S-HD

NOTE: Given height is for unit without a Metro dolly or casters.

NOTE: To calculate the actual height of the unit using plate casters: 62" (1575 mm) + 1/4" (6 mm) for dolly + load height of the caster.

Dolly bases are recommended for applications where security units will be transported over the road.

Please consult your VWR representative for the appropriate casters and accessories for these applications.

Intermediate Shelves for Super Erecta® Shelf Security Units

Width inch	Width mm	Length inch	Length mm	Approx. Pkd. Wt. lbs	Approx. Pkd. Wt. kg	Cat. No Chrome	MICROBAN® Cat. No. Metroseal 3 with Microban	Cat. No Stainless Steel
18	457	36	914	9 1/2	4.3	A1836NC	1836NK3	A1836NS
18	457	48	1219	12	5.4	A1848NC	1848NK3	A1848NS
24	610	36	914	13	6	A2436NC	2436NK3	A2436NS
24	610	48	1219	16	7	A2448NC	2448NK3	A2448NS
24	610	60	1524	21	9.5	A2460NC	2460NK3	A2460NS

NOTE: Standard Super Erecta® shelves can also be used as intermediate shelves.



Unit shown with optional Super Adjustable™ intermediate shelves (sold separately). Doors rotate 270° and can be secured to the sides of the cart while contents are being loaded on the shelves.

Metro Tip:

For highly corrosive environments, choose casters constructed of appropriate materials. While most wheels are corrosion resistant, the horns and axles are not. Select from a variety of Metro casters with polymer and stainless components.

MetroMax® Q

Security.

MetroMax Q Security Units

Protects valuable materials and sensitive items from loss or pilferage.

- Ready view of contents: Heavy gauge open wire construction keep contents visible at all times, making it easy to check inventory.
- Microban antimicrobial product protection is built into the enclosures, doors, handles, and shelves to keep the product “cleaner between cleanings.”
- Optional intermediate shelves: MetroMax Q quick adjust shelves or corrosion proof MetroMax i.
- Double door with ergonomic ¼-turn handle: Each door opens 270 degrees and can be secured along the sides of the unit.
- Shipped knocked down to save on freight costs. Assembles in minutes.



MQSEC53VE with optional intermediate shelves

MetroMax Q Stationary Units — 66 3/16" (1681mm) High

Actual Outside Dimensions (including Bumpers and Handle)				Fits Shelf		Approx. Pkd. Wt.		Cat. No.
Length		Width		(in.)	(mm)	(lbs.)	(kg)	
(in.)	(mm)	(in.)	(mm)	(in.)	(mm)	(lbs.)	(kg)	
26 15/16	685	38 7/8	987	24x36	610x914	148	67	MQSEC53E
26 15/16	685	50 7/8	1292	24x48	610x1219	156	71	MQSEC55E
26 15/16	685	62 7/8	1597	24x60	610x1524	161	73	MQSEC56E

Note: Leveling foot on post can be adjusted up to 1" (25mm) to compensate for uneven floors.

Standard Units consist of top and bottom wire shelves, tri-lobal adapters, steel posts, wire enclosures, and doors. Casters are included with mobile units. Intermediate shelves are sold separately.

MetroMax Q Stem Caster Mobile Units — 67 13/16" (1723mm) High

Models include four 5" (127mm) diameter casters with polyurethane tread; two swivel and two swivel with brakes.

Actual Outside Dimensions (including Bumpers and Handle)				Fits Shelf		Approx. Pkd. Wt.		Cat. No. Includes Casters with Plated Finish	Cat. No. Includes Corrosion Resistant Polymer Casters
Length		Width		(in.)	(mm)	(lbs.)	(kg)		
(in.)	(mm)	(in.)	(mm)	(in.)	(mm)	(lbs.)	(kg)		
27 13/16	707	40 3/4	1035	24x36	610x914	166	75	MQSEC53DE	MQSEC53VE
27 13/16	707	52 3/4	1340	24x48	610x1219	176	80	MQSEC55DE	MQSEC55VE
27 13/16	707	64 3/4	1645	24x60	610x1524	179	81	MQSEC56DE	MQSEC56VE

**“DE” models use two 5MPX and two 5MPBX casters.
 ***“VE” models use two 5PCX and two 5PCBX casters. Recommended for wet or damp environments.



Ergonomic — ¼ turn door handle

MetroMax Q Heavy-Duty Mobile Units — 68 1/2" (1740mm) High

Mounted on aluminum dolly with 5" (127mm) plate casters and wraparound bumpers.

Actual Outside Dimensions (including Handle)				Fits Shelf		Approx. Pkd. Wt.		Cat. No.
Width		Length		(in.)	(mm)	(lbs.)	(kg)	
(in.)	(mm)	(in.)	(mm)	(in.)	(mm)	(lbs.)	(kg)	
28 1/16	713	39 1/8	994	24x36	610x914	166	75	MQSEC53LE
28 1/16	713	51 1/8	1299	24x48	610x1219	176	80	MQSEC55LE
28 1/16	713	63 1/8	1603	24x60	610x1524	179	81	MQSEC56LE

Note: The aluminum dollies used on the LE models have two B5P and two B5PB plate casters.

Intermediate Shelves

				i	i	Q
Width		Length		Cat. No. Shelf with Grid Mat	Cat. No. Shelf with Solid Mat	Cat. No. Shelf with Grid Mat
(in.)	(mm)	(in.)	(mm)			
24	610	36	914	MX2436G	MX2436F	MQ2436G
24	610	48	1220	MX2448G	MX2448F	MQ2448G
24	610	60	1524	MX2460G	MX2460F	MQ2460G



Easy to access. Hard to steal.



20

No need for users
to carry a key

Unique codes
supported

Keep valuable items safe at your fingertips...no keys required.

Metro security shelving units with PIN lock system protect valuable, sensitive items from wandering off. Contents are easily viewable but yet... safe. Heavy gauge wire keeps contents secure but highly visible for inventory management. The PIN locking system allows you to store up to 20 codes for access tracking or employee turnover measures. Plus, the added convenience of not needing to track and locate misplaced keys.

Additional Benefits:

Durable: Chrome plated, stainless and rust resistant finishes offer durability choices to fit your application.

Flexible: Available models offer optional middle wire shelves for more storage. Metroseal Green and MetroMax Q models can accommodate intermediate shelves with durable, removable polymer shelf mats.

Easy Cleaning: Mobile units allow thorough cleaning of floors & walls while optional intermediate removable mat shelves offer the easiest cleanability.

Microban® Antimicrobial Product Protection: Metroseal Green and MetroMax Q models feature Microban Antimicrobial Product Protection, designed to stay "cleaner between cleanings."

Safe Transportation: Mobile, security trucks provide the advantage of quick, protective transportation.



Easy to clean
keypad

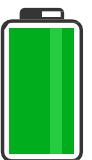

5+ years
battery life



Electronic PIN lock is available on over 50 Metro security shelving models.

Electronic PIN Locking System

Allow users to access the contents of the cart without worrying about losing or possessing traditional keys. It provides fast and easy access for up to 19 users and 1 supervisor using unique 4-8 digit codes. PIN lock is low maintenance with 5+ years battery life and hassle free with no software or feature programming making it simple to use and easy to maintain. Epoxy coated lock chassis is suitable for basic rust resistant storage requirements.

Secure valuables & free aisle space.

Security Shelving
with *SlideSecure*



Keep your aisles open and access unobstructed with sliding door security.

Metro *SlideSecure* Space Saving Doors provide the same level of protection as traditional security units with the space saving convenience of our sliding door system. Choose sliding security in either high traffic or cramped areas.

Plus, Metro's exclusive sliding door system can also be integrated into our high-density track systems.



Super Erecta® Security with *SlideSecure* Doors in Metroseal Green Finish

Swing-Out Door

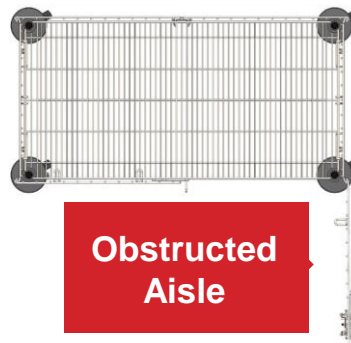

Obstructed
Aisle

Sliding Door

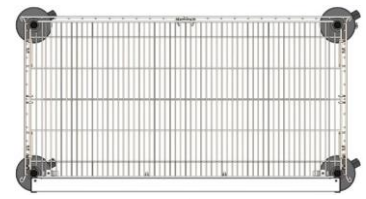

Open Aisle

Easier Access without doors
obstructing each other.

Secure valuables even in track applications.

Metro exclusive!

Security units can be added to our high-density track shelving in both Super Erecta® and MetroMax® Q shelving styles.



EZ-ADD
COMPATIBLE

ADD A SHELF
WITHOUT TOOLS
OR DISMANTLING
YOUR SHELVING

Compatible with Super Erecta® style only.
EZ-ADD shelves available in chrome and Metroseal green finishes.

Metro Shelving

TableWorx™

Nothing Gets in the Way of Productivity

Metro's TableWorx™ worktables are designed to meet the demands of various industrial and laboratory environments. Engineered with durability and versatility in mind, these workstations feature robust construction and customizable configurations with a range of sizes and materials.

08

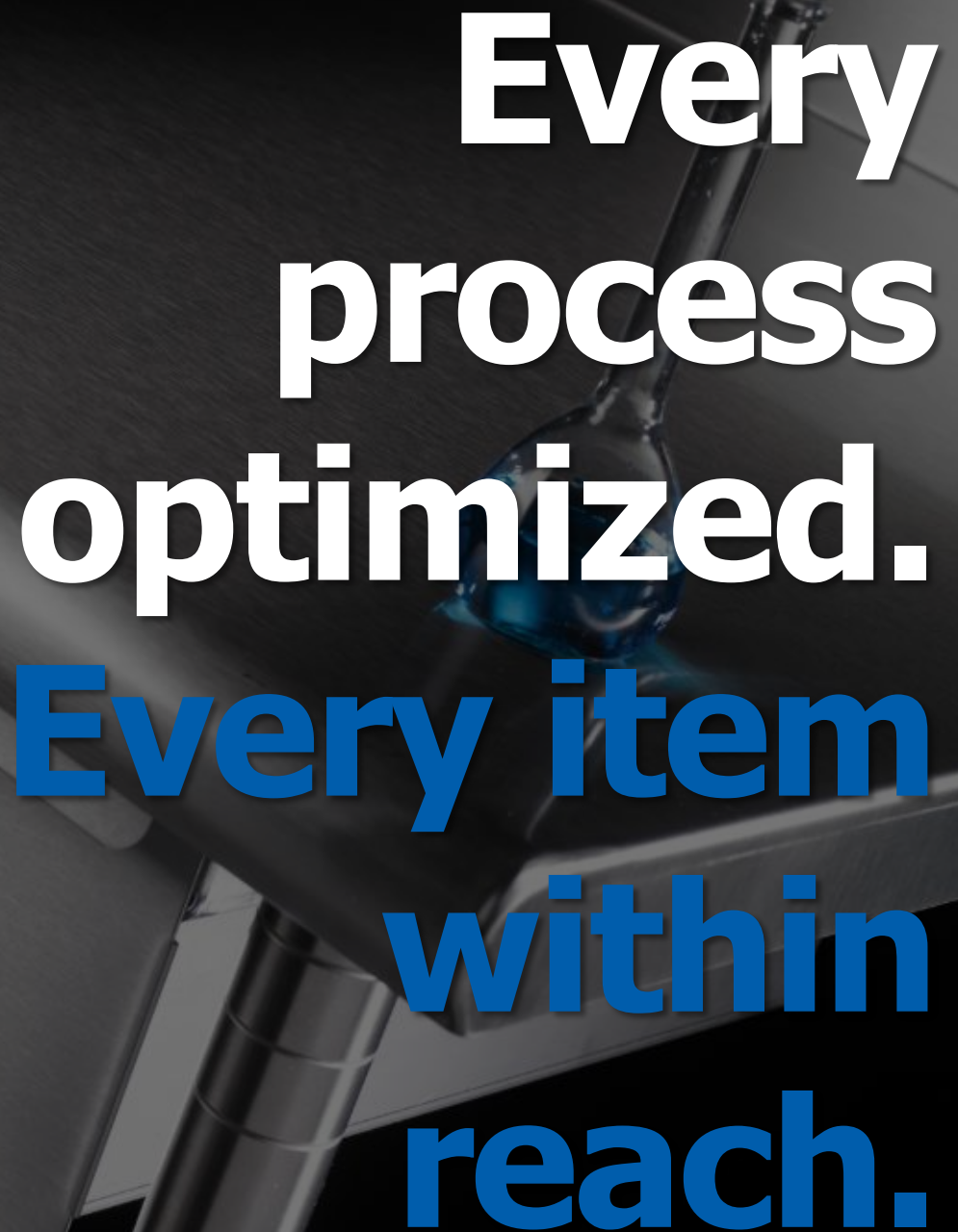

**Every
process
optimized.
Every item
within
reach.**

TableWorx™ Worktables

TableWorx™ Performance Worktables

- Innumerable options and a truly modular platform allow you to customize a perfect solution
- Overhead riser solution can be added at anytime during the life of the worktable converting it into a productivity workcenter
- Height adjustability built into every table

Adaptive worktables that maximize efficiency above & below the surface.



TableWorx All-Stainless Worktable
Shown with solid stainless bottom shelf

TableWorx All-Stainless Worktable
Shown with riser system, Solid stainless upper shelf and solid bottom shelf

Three levels of materials to match performance with process requirements

<p>Standard Perfect for foodservice, academic, and general use purposes</p>	<p>All Stainless Perfect for lab, electronics, pharmaceutical, and general life science applications</p>	<p>316 Stainless Perfect for cleanroom, biopharma, and other applications with demanding cleaning protocols</p>
--	---	--

Component	Standard	All Stainless	316 All Stainless
Work Surface Material	Type 304 Stainless	Type 304 Stainless	Type 316 Stainless
Leg Material	Metroseal Gray Epoxy Coated Steel	Type 304 Stainless	Type 304 Stainless
Leg Mount Material	Nylon	Type 304 Stainless	Type 304 Stainless



All tables available in stationary or mobile-ready options.



Warranty: 1-year parts & labor warranty



Specifications

Worksurface

- Surface consists of 16-gauge stainless steel with a #4 finish
- Reinforced with 16-gauge hat channels
- Work surface alloy: type 304 or 316 stainless
- Surface load rating is 650 lbs. (295 kg) evenly distributed
- Work surface features 90-degree turned down edges with radii on all four sides
- All sizes available with an optional 2" (51 mm) backsplash formed into the stainless work surface

Available Sizes

Widths	Lengths						
	24" (610 mm)	30" (762 mm)	36" (914 mm)	48" (1219 mm)	60" (1524 mm)	72" (1829 mm)	96" (2438 mm)
24" (610 mm)	X	X	X	X	X	X	X
30" (762 mm)	-	X	X	X	X	X	X
36" (914 mm)	-	-	X	X	X	-	-

TableWorx™ Worktables – Add-Ons

Work Surface Height Adjustability

- Ergonomics: Perfect seated height or standing height in EVERY TableWorx solution
- Out of the box TableWorx can be assembled to any one of six working surface heights: 34" (864 mm), 35" (889 mm), 36" (914 mm), 37" (940 mm), 38" (965 mm), and 39" (991 mm)
- Work surface heights are the same across both stationary and mobile solutions (assuming use of 5" stems casters)

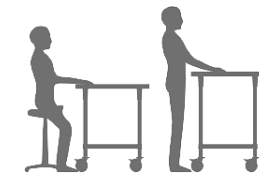

6 ADJUSTABLE
Working Heights
34" — 39"
(864mm – 991mm)

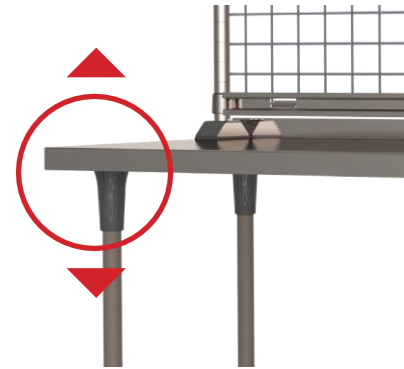

Under Structure

- Available solutions:
 - > Solid stainless under shelf
 - > Three-sided frame
 - > I-frame (H-frame)
- All-welded, all-stainless steel construction
- Under frame material: Type 304 stainless steel
- Under structures can be assembled to varying heights to table legs in 2" (51 mm) increments
- Multiple solid stainless under shelves can be installed to increase available storage underneath

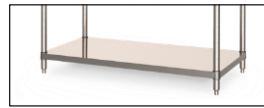

Solid Stainless Bottom Shelf
Base accommodates multiple shelves



3-Sided Frame
To nest equipment or when seated



"I" Frame
Perfect for foot rest or 2-sided access

Worktable Legs

- Leg Material: 16-gauge type 304 stainless steel or Metroseal Gray epoxy coated 16-gauge cold rolled steel
- Metroseal Gray epoxy finish has built-in Microban® antimicrobial protection. 12-Year corrosion warranty
- Leg Mount Material: Type 304 stainless steel or reinforced nylon polymer
- Legs: Outer Diameter: 1-5/8" (41 mm) Lengths: 32" (813 mm) stationary and 27" (686 mm) for mobile
- Mobile legs can accept any Metro 1" (25 mm) stem caster
- Mobile legs include caster stem locking feature to utilize total-lock casters
- Stationary legs include stainless leveling bullet feet with 1-1/8" (29 mm) range of adjustability

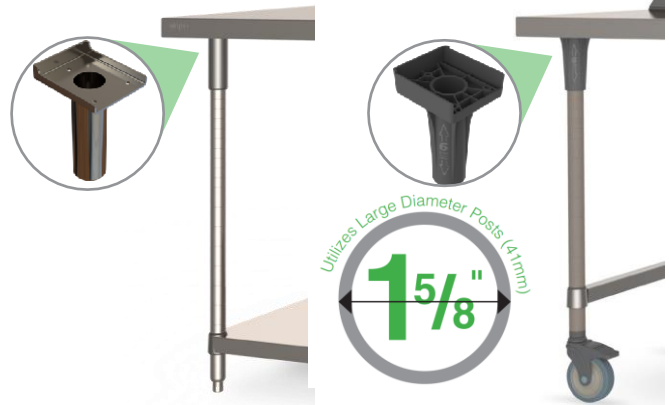

304 Stainless Steel Post
Shown in stationary with Stainless steel leg mount

Metroseal Epoxy Coated Post
Shown in mobile with polymer leg mount



Under Structure

- Available solutions:
 - > Solid stainless under shelf
 - > Three-sided frame
 - > I-frame (H-frame)
- All-welded, all-stainless steel construction
- Under frame material: Type 304 stainless steel
- Under structures can be assembled to varying heights to table legs in 2" (51 mm) increments
- Multiple solid stainless under shelves can be installed to increase available storage underneath

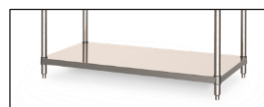

Solid Stainless Bottom Shelf
Base accommodates multiple shelves



3-Sided Frame
To nest equipment or when seated



"I" Frame
Perfect for foot rest or 2-sided access

TableWorx™ Worktables – Add-Ons

Overhead Riser System

- Installed or removed at anytime during life of worktable
- Remains within worktable footprint
- Cantilevered with only two rear mounting posts
- Can mount at rear of or in the center of worktable
- Solution can be shelving, SmartWall grid, or combination of Shelf and SmartWall grid
- Grid hanging rail doubles as a bin holder for the entire length of table

Shelf and Grid Options

- **Solid stainless shelves:** 12" deep rear or center cantilevered, Type 304 or 316 stainless
- **Wire DropMat shelving** 12" deep type 304 stainless wire
- **SmartWall Grid:** 24" high Metroseal Gray Epoxy Coated or type 304 stainless steel
- Mounting post are type 304 stainless steel with type 316 stainless base

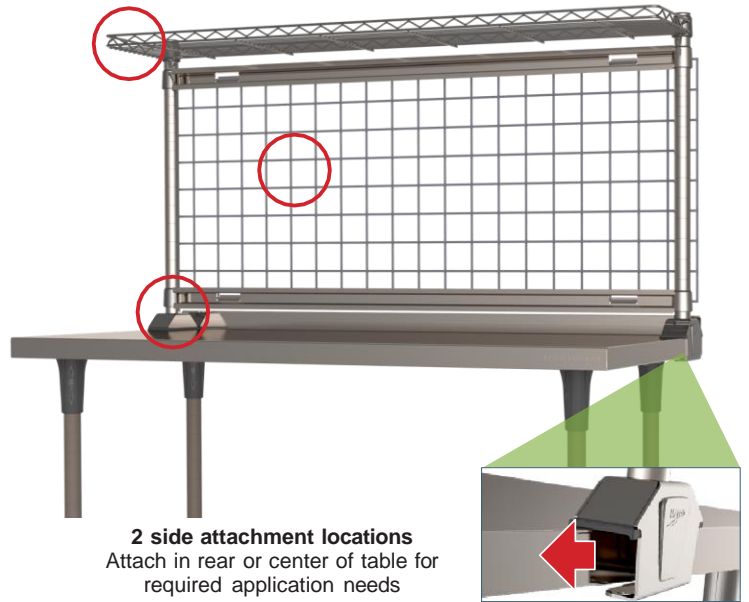

2 side attachment locations
Attach in rear or center of table for required application needs

Dimensional Specifications

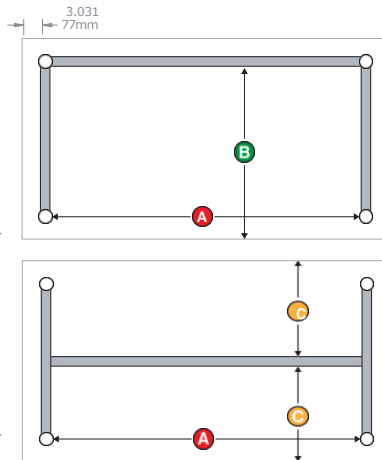
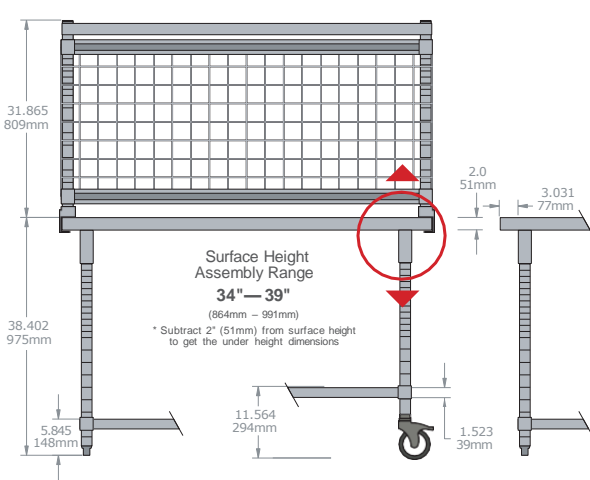
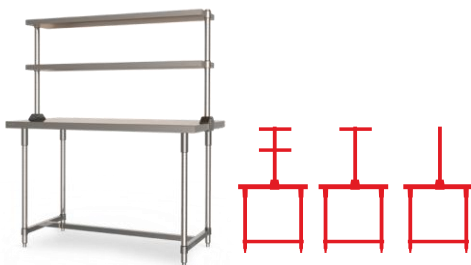

Table Top Size in (mm)	A	B	C
24 (610) x 24 (610)	13.7 (348)	20.2 (513)	11.3 (287)
24 (610) x 30 (762)	19.7 (500)	20.2 (513)	11.3 (287)
24 (610) x 36 (914)	25.7 (653)	20.2 (513)	11.3 (287)
24 (610) x 48 (1219)	37.7 (958)	20.2 (513)	11.3 (287)
24 (610) x 60 (1524)	49.7 (1262)	20.2 (513)	11.3 (287)
24 (610) x 72 (829)	61.7 (1567)	20.2 (513)	11.3 (287)
24 (610) x 96 (2438)	85.7 (2177)	20.2 (513)	11.3 (287)
30 (762) x 30 (762)	19.7 (500)	24.2 (615)	14.3 (363)
30 (762) x 36 (914)	25.7 (653)	24.2 (615)	14.3 (363)
30 (762) x 48 (1219)	37.7 (958)	24.2 (615)	14.3 (363)
30 (762) x 60 (1524)	49.7 (1262)	24.2 (615)	14.3 (363)
30 (762) x 72 (829)	61.7 (1567)	24.2 (615)	14.3 (363)
30 (762) x 96 (2438)	85.7 (2177)	24.2 (615)	14.3 (363)
36 (914) x 36 (914)	25.7 (653)	30.2 (767)	17.25 (438)
36 (914) x 48 (1219)	37.7 (958)	30.2 (767)	17.25 (438)
36 (914) x 60 (1524)	49.7 (1262)	30.2 (767)	17.25 (438)

Riser Mounting Options



Center Mount

Choose accessory grid only, center-mount solid stainless over-shelves, or a combination of both.



Rear Mount

Choose accessory grid only, stainless solid or wire over-shelves, or a combination of both.

TableWorx™ Worktables – Casters

Caster Options

 **GOOD**

 **BETTER**

 **BEST**



5MDBA-NB
Plated Caster with High Modulus Tread
 For dry environments and for medium duty applications. Non-marking high modulus donut tread and polyolefin hub. Plated horns, stems, axles, and brakes. Ball bearing swivel and axle.



5MPB-NB
Plated Caster with Polyurethane Tread
 For dry environments and for medium duty applications. Non-marking polyurethane flat tread & polyethylene hub. Chrome plated horns, stems, axles, and brakes (optional). Ball bearing swivel and axle.



5PCB-NB
Standard Polymer Caster
 Basic corrosion protection for wet environments. Reinforced nylon rig with chromate plated stem and swivel raceway.
Maintenance Free: Sealed swivel ball bearings and Delrin axle bearings.
BASIC CORROSION RESISTANCE
NOT SUITED FOR SPRAY SERIALIZATION, HIGH HUMIDITY, HI-TEMP CART WASH.



BEST ALL AROUND
5PSTEB-NB
Polymer/Stainless Total-Guard Caster
 High-rust protection with reinforced nylon rig, stainless steel stem and hardware. Non-marking polyurethane flat tread & polyethylene hub.
EXCELLENT CHEMICAL & CORROSION RESISTANCE. BEST FOR: HIGH-HUMIDITY, HIGH SALT EXPOSURE, MRI, RFID, CART WASH
NOT SUITED FOR ACID EXPOSURE



5MPBGSA
Premium Type 304 Stainless Steel Caster
 Type 304 Stainless Steel Rig, Hardware and sealed SS bearings.
EXCELLENT & CHEMICAL CORROSION RESISTANCE. BEST FOR: HI-TEMP CART WASH UP TO 180F

Wheel Diameter		Face		Load Rating		Type	Wheel Tread	Temperature range (continuous)		Cat. No.
(in.)	(mm)	(in.)	(mm)	(lbs.)	(kg)			(Fahrenheit)	(Celsius)	
5	127	1.25	32	300	135	Stem/Brake	High Modulus Donut	-20° - 180°	-29° - 82°	5MDBA-NB
5	127	1.25	32	300	135	Stem/Brake	Polyurethane, Flat	-20° - 180°	-29° - 82°	5MPB-NB
5	127	1.25	32	300	135	Stem/Brake	Polyurethane, Flat	-20° - 120°	-29° - 49°	5PCB-NB
5	127	1.25	32	250	113	Stem/Brake	TPE, Flat	-20° - 120°	-29° - 49°	5PSTEB-NB
5	127	1.25	32	250	113	Stem/Brake	High Modulus Donut	-20° - 120°	-29° - 49°	5MDBGSA
6	127	1.25	32	250	113	Stem/Brake	Polyurethane, Flat	-20° - 120°	-29° - 49°	5MPBGSA

TableWorx accepts any Metro 1" stem caster available. Selected caster solution comes with four brake casters



MOBILE READY WORKTABLES DO NOT COME WITH CASTERS. CASTERS MUST BE ORDERED SEPARATELY.

TableWorx™ Worktables – Options



ALL-STAINLESS WORKTABLES

Type 304 Stainless Work Surface / Type 304 Stainless Components

Worktable Width	Worktable Length in (mm)	Stationary			Mobile Ready (Casters Must Be Ordered Separately)		
		Solid Stainless Shelf	3-Sided Frame	Stainless I-Frame	Solid Stainless Shelf	3-Sided Frame	I-Frame
24" (610 mm)	24 (610)	TWS2424FS-304-S	TWS2424SU-304-S	TWS2424SI-304-S	TWM2424FS-304-S	TWM2424SU-304-S	TWM2424SI-304-S
	30 (762)	TWS2430FS-304-S	TWS2430SU-304-S	TWS2430SI-304-S	TWM2430FS-304-S	TWM2430SU-304-S	TWM2430SI-304-S
	36 (914)	TWS2436FS-304-S	TWS2436SU-304-S	TWS2436SI-304-S	TWM2436FS-304-S	TWM2436SU-304-S	TWM2436SI-304-S
	48 (1219)	TWS2448FS-304-S	TWS2448SU-304-S	TWS2448SI-304-S	TWM2448FS-304-S	TWM2448SU-304-S	TWM2448SI-304-S
	60 (1524)	TWS2460FS-304-S	TWS2460SU-304-S	TWS2460SI-304-S	TWM2460FS-304-S	TWM2460SU-304-S	TWM2460SI-304-S
	72 (1829)	TWS2472FS-304-S	TWS2472SU-304-S	TWS2472SI-304-S	TWM2472FS-304-S	TWM2472SU-304-S	TWM2472SI-304-S
	96 (2438)	TWS2496FS-304-S	TWS2496SU-304-S	TWS2496SI-304-S	TWM2496FS-304-S	TWM2496SU-304-S	TWM2496SI-304-S
30" (762 mm)	30 (762)	TWS3030FS-304-S	TWS3030SU-304-S	TWS3030SI-304-S	TWM3030FS-304-S	TWM3030SU-304-S	TWM3030SI-304-S
	36 (914)	TWS3036FS-304-S	TWS3036SU-304-S	TWS3036SI-304-S	TWM3036FS-304-S	TWM3036SU-304-S	TWM3036SI-304-S
	48 (1219)	TWS3048FS-304-S	TWS3048SU-304-S	TWS3048SI-304-S	TWM3048FS-304-S	TWM3048SU-304-S	TWM3048SI-304-S
	60 (1524)	TWS3060FS-304-S	TWS3060SU-304-S	TWS3060SI-304-S	TWM3060FS-304-S	TWM3060SU-304-S	TWM3060SI-304-S
	72 (1829)	TWS3072FS-304-S	TWS3072SU-304-S	TWS3072SI-304-S	TWM3072FS-304-S	TWM3072SU-304-S	TWM3072SI-304-S
	96 (2438)	TWS3096FS-304-S	TWS3096SU-304-S	TWS3096SI-304-S	TWM3096FS-304-S	TWM3096SU-304-S	TWM3096SI-304-S
36" (914 mm)	36 (914)	TWS3636FS-304-S	TWS3636SU-304-S	TWS3636SI-304-S	TWM3636FS-304-S	TWM3636SU-304-S	TWM3636SI-304-S
	48 (1219)	TWS3648FS-304-S	TWS3648SU-304-S	TWS3648SI-304-S	TWM3648FS-304-S	TWM3648SU-304-S	TWM3648SI-304-S
	60 (1524)	TWS3660FS-304-S	TWS3660SU-304-S	TWS3660SI-304-S	TWM3660FS-304-S	TWM3660SU-304-S	TWM3660SI-304-S

NOTE: For optional 2" backplash add "B" suffix to surface material designation. Ex. TWS3648FS-304B-K



316 ALL-STAINLESS WORKTABLES

Type 316 Stainless Work Surface / Type 304 Stainless Components

Worktable Width	Worktable Length in (mm)	Stationary			Mobile Ready (Casters Must Be Ordered Separately)		
		Solid Stainless Shelf	3-Sided Frame	Stainless I-Frame	Solid Stainless Shelf	3-Sided Frame	I-Frame
24" (610 mm)	24 (610)	TWS2424FS-316-S	TWS2424SU-316-S	TWS2424SI-316-S	TWM2424FS-316-S	TWM2424SU-316-S	TWM2424SI-316-S
	30 (762)	TWS2430FS-316-S	TWS2430SU-316-S	TWS2430SI-316-S	TWM2430FS-316-S	TWM2430SU-316-S	TWM2430SI-316-S
	36 (914)	TWS2436FS-316-S	TWS2436SU-316-S	TWS2436SI-316-S	TWM2436FS-316-S	TWM2436SU-316-S	TWM2436SI-316-S
	48 (1219)	TWS2448FS-316-S	TWS2448SU-316-S	TWS2448SI-316-S	TWM2448FS-316-S	TWM2448SU-316-S	TWM2448SI-316-S
	60 (1524)	TWS2460FS-316-S	TWS2460SU-316-S	TWS2460SI-316-S	TWM2460FS-316-S	TWM2460SU-316-S	TWM2460SI-316-S
	72 (1829)	TWS2472FS-316-S	TWS2472SU-316-S	TWS2472SI-316-S	TWM2472FS-316-S	TWM2472SU-316-S	TWM2472SI-316-S
	96 (2438)	TWS2496FS-316-S	TWS2496SU-316-S	TWS2496SI-316-S	TWM2496FS-316-S	TWM2496SU-316-S	TWM2496SI-316-S
30" (762 mm)	30 (762)	TWS3030FS-316-S	TWS3030SU-316-S	TWS3030SI-316-S	TWM3030FS-316-S	TWM3030SU-316-S	TWM3030SI-316-S
	36 (914)	TWS3036FS-316-S	TWS3036SU-316-S	TWS3036SI-316-S	TWM3036FS-316-S	TWM3036SU-316-S	TWM3036SI-316-S
	48 (1219)	TWS3048FS-316-S	TWS3048SU-316-S	TWS3048SI-316-S	TWM3048FS-316-S	TWM3048SU-316-S	TWM3048SI-316-S
	60 (1524)	TWS3060FS-316-S	TWS3060SU-316-S	TWS3060SI-316-S	TWM3060FS-316-S	TWM3060SU-316-S	TWM3060SI-316-S
	72 (1829)	TWS3072FS-316-S	TWS3072SU-316-S	TWS3072SI-316-S	TWM3072FS-316-S	TWM3072SU-316-S	TWM3072SI-316-S
	96 (2438)	TWS3096FS-316-S	TWS3096SU-316-S	TWS3096SI-316-S	TWM3096FS-316-S	TWM3096SU-316-S	TWM3096SI-316-S
36" (914 mm)	36 (914)	TWS3636FS-316-S	TWS3636SU-316-S	TWS3636SI-316-S	TWM3636FS-316-S	TWM3636SU-316-S	TWM3636SI-316-S
	48 (1219)	TWS3648FS-316-S	TWS3648SU-316-S	TWS3648SI-316-S	TWM3648FS-316-S	TWM3648SU-316-S	TWM3648SI-316-S
	60 (1524)	TWS3660FS-316-S	TWS3660SU-316-S	TWS3660SI-316-S	TWM3660FS-316-S	TWM3660SU-316-S	TWM3660SI-316-S

NOTE: For optional 2" backplash add "B" suffix to surface material designation. Ex. TWS3648FS-304B-K



**Customize,
optimize,
revolutionize
your space.**

Metro Shelving

Ready-to-Implement Laboratory Solutions

09

Laboratory Solutions

Metro Shelving offers the perfect solutions for creating ideal modular, turnkey laboratory furniture, ensuring everything is in optimally place for a functional and efficient workspace.



Change the way you work.

Built with high-quality materials and precision engineering in its design and production, Metro Shelving's laboratory furniture promises durability, efficiency, customization, and a professional environment conducive to scientific excellence.

- **GOWNING:** Metro's gowning stations ensure organized and sanitary storage for cleanroom apparel.
- **CASEVUE:** CaseVue cabinets offer clear visibility and secure storage for sensitive equipment.
- **FLEXLINE:** Flexline carts deliver durable and customizable mobility for streamlined workflow management.
- **STARSYS:** Starsys modular storage solutions provide versatile and efficient organization for various environments.

Gowning solutions that fit perfectly.

TYPE
304
STAINLESS STEEL

All new gowning bench sizes, and accessories.

Type 304 Stainless Steel, H.D. Super Posts and Proven Super Erecta® Construction Throughout.

- › Heavy-duty, solid top bench provides a sturdy and comfortable gowning fixture. All benches are 18" (457mm) tall.
- › Adjustable stainless steel foot plates provide for floor mounting. Floor mounting necessary for 9" and 12" wide benches.
- › Unit is non-conductive but can be made conductive with the addition of H.D. Aluminum Split Sleeves (9986HZ).

NEW Smaller Sizes

Model No.	Dimensions inch (W X L)	Dimensions mm (W X L)	Approx. Pkd. Wt. lbs	Approx. Pkd. Wt. kg
GB936S	9x36	229x914	60.2	27.3
GB948S	9x48	229x1219	66.7	30.3
GB960S	9x60	229x1524	72.9	33.1
GB972S	9x72	229x1825	79.1	35.9
GB1224S	12x24	305x610	56.5	25.6
GB1236S	12x36	305x914	63.4	28.7
GB1248S	12x48	305x1219	70.3	31.8
GB1260S	12x60	305x1524	77.2	35.1
GB1272S	12x72	305x1829	84.1	84.1

Original Sizes

GB1636S	16x36	406x914	72.1	32.7
GB1648S	16x48	406x1219	79.3	35.9
GB1660S	16x60	406x1524	89.5	40.6
GB1672S	16x72	406x1825	91.5	41.5

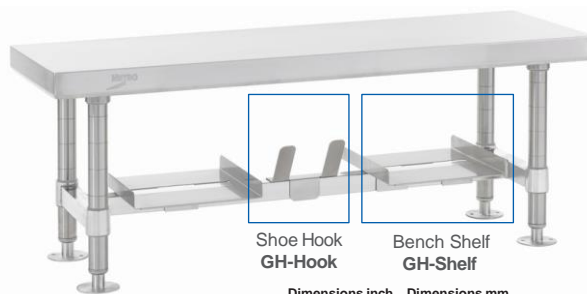

Model No.	Dimensions inch (W X L)	Dimensions mm (W X L)
GB-Hook	6x5	152x127
GB-Shelf	10x11	254x280

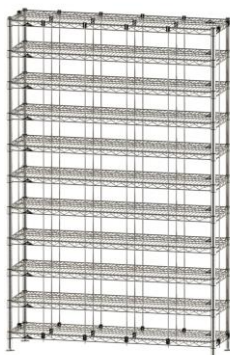

Bootie/Shoe Rack

Customized compartments to fit your needs. Metro Super Erecta® shelving can be customized for many specific storage and handling tasks. To store cleanroom booties or shoes the following standard components may be combined to create a stainless steel storage rack as shown.

- › Available in electro-polished, Type 304 stainless steel or chrome
- › Open-wire design maintains laminar air flow
- › High-density storage
- › Optional snap-on label holder

Model No.	Dimensions inch (W X L)	Dimensions mm (W X L)
CRLS13NSBS	14x36x74	355x914x1879
CRLS15NSBS	14x48x74	355x1219x1879
CRLS16NSBS	14x60x74	355x1524x1879

ESD Classification: Non-Conductive (Units can be made conductive with the addition of conductive plastic split sleeves.)

Gowning Room Racks & Storage

Upright & wall-mounted gowning racks.

Racks are designed to provide efficient storage of Cleanroom garments. Hangers are spaced at 3" (75 mm) intervals. Electro-polished, Type 304 stainless steel hangers are included. Upright units are approximately 74" (1879 mm) high, wall mount units are 7 1/2" (190 mm) high.

- > Type 304 stainless steel and proven Super Erecta® construction throughout.
- > Floor-mountable upright and wall-mounted versions available.
- > Open wire construction promotes laminar air flow.
- > Electro-polished, Type 304 stainless steel hangers are included. Hangers are spaced at 3" (76mm) intervals.
- > Unique hanger capture mechanism provides theft deterrence.
- > Easy to assemble.
- > Adjustable stainless steel triangular foot plates provided for floor mounting.
- > Available in several sizes to suit your requirements.
- > Upright unit is non-conductive, but can be made conductive with the addition of aluminum split sleeves (9986Z).

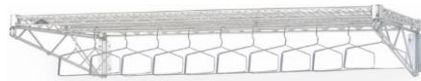

Wall-Mounted Racks - 7.5" (191mm) Tall

Model No.	Shelf Size inch (W X L)	Shelf Size mm (W X L)	No. of Hangers	Approx. Pkd. Wt. lbs	Approx. Pkd. Wt. kg
GRW2436S	24x36	610x914	11	20	9.0
GRW2448S	24x48	610x1219	15	22.5	10.2
GRW2460S	24x60	610x1524	19	27.5	12.5
GRW2472S	24x72	610x1825	23	32	14.5

Upright Racks - 74.625" (1895mm) Tall

Model No.	Shelf Size inch (W X L)	Shelf Size mm (W X L)	No. of Hangers	Approx. Pkd. Wt. lbs	Approx. Pkd. Wt. kg
GRU2436S	24x36	610x914	11	27	12.25
GRU2448S	24x48	610x1219	15	36	16.25
GRU2460S	24x60	610x1524	19	45	20.50
GRU2472S	24x72	610x1825	23	54	24.50

MetroMax i® Gown and Bootie Storage

Baskets have semi-open front for easy access. Dividers adjust horizontally within the basket to accept various sizes.

Continuous label holders identify basket contents.

Description	Dimensions inch*	Dimensions mm*	Total Baskets per Cart	Casters (see below)	Cat. No.
Open Cart	24 x 24 x 60	610 x 610 x 1524	4	*	MXIV1
Open Cart with Top Shelf	24 x 24 x 69	610 x 610 x 1753	4	*	MXIV2
Open Cart	24 x 42 x 60	610 x 1066 x 1524	8	†	MXIV4
Open Cart with Top Shelf	24 x 42 x 69	610 x 1066 x 1753	8	†	MXIV5
Open Cart	24 x 60 x 60	610 x 1524 x 1524	12	†	MXIV6
Open Cart with Top Shelf	24 x 60 x 69	610 x 1524 x 1753	12	†	MXIV7

* Four 5" (127 mm) poly casters; two swivel, two with brakes.

† 5" (127 mm) poly casters on dolly frame; two swivel, one swivel with brake, and one rigid.



(shown with)



Baskets fit on frames level or at a 10° angle for easy viewing.

Accessories

Description	Dimensions inch	Dimensions mm	Cat. No.
Basket* with Label Holder	18 1/2 x 24 1/2 x 10	470 x 622 x 254	IVB1
Divider	9	229	IVBD

* Basket weight capacity is 35 lbs. (16kg). Finish is epoxy; color is taupe.

One look and the advantage is clear.



All components including handles, casters, body, doors, interior are type 304 stainless steel for superior corrosion protection.

CaseVue™ –

Lab carts

The most durable, ergonomic and efficient family of lab carts ever delivered.

Built for easy transport, Metro CaseVue™ is stronger, lighter, and the most ergonomic choice available. Robust multi-handle design and 5th wheel steering allows users, of any stature, to easily maneuver supplies on or off-site. Well-appointed to support the sterile instrument transport process with features like clear-view doors, quick-view status indicators, and a swing-up transport handle. Get a better perspective on your sterile workflow with Metro CaseVue.



Better access.

Shelves pull out further than any other providing better access to lift and retrieve items.

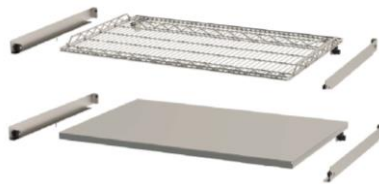

Fluid Retaining Floor.



Floor is sealed with silicone and raised front edge retains spills. Tilting action of cart washer and weep holes ensure water evacuates.



Reduce noise.

Metro CaseVue is designed specifically to be the quietest cart in motion, to help maintain staff and patient satisfaction.



Touch with confidence.

Cool touch handles: Eliminate the need for protective cloth to remove cart from cart wash. Antimicrobial for confidence anytime.



CaseVue™ Laboratory Carts

CaseVue™
Lab carts



Clear Door Carts

Preconfigured Carts with Shelves, Accessories and 5th Wheel

Cat. No Wire Shelf	Cat. No Solid Shelf	Description	L x W x H (inch.)	L x W x H (mm)
CV36LC-5BFH-W1	CV36LC-5BFH-S1	Case Cart, Low, Clear Doors, 5th Wheel, Accessories, 1 Shelf	28 x 45.5 x 40.62	711 x 1156 x 1032
CV48LC-5BFH-W1	CV48LC-5BFH-S1	Case Cart, Low, Clear Doors, 5th Wheel, Accessories, 1 Shelf	28 x 57.5 x 40.62	711 x 1461 x 1032
CV36HC-5BFH-W2	CV36HC-5BFH-S2	Case Cart, High, Clear Doors, 5th Wheel, Accessories, 2 Shelves	28 x 45.5 x 58.25	711 x 1156 x 1480

Preconfigured Carts with Shelves and Accessories

Cat. No Wire Shelf	Cat. No Solid Shelf	Description	L x W x H (inch.)	L x W x H (mm)
CV24LC-NBF-W1	CV24LC-NBF-S1	Case Cart, Low, Clear Door, Accessories, 1 Shelf	28 x 33.5 x 40.62	711 x 851 x 1032
CV36LC-NBFH-W1	CV36LC-NBFH-S1	Case Cart, Low, Clear Doors, Accessories, 1 Shelf	28 x 45.5 x 40.62	711 x 1156 x 1032
CV48LC-NBFH-W1	CV48LC-NBFH-S1	Case Cart, Low, Clear Doors, Accessories, 1 Shelf	28 x 57.5 x 40.62	711 x 1461 x 1032
CV24HC-NBFH-W2	CV24HC-NBFH-S2	Case Cart, High, Clear Door, Accessories, 2 Shelves	28 x 33.5 x 58.25	711 x 851 x 1480
CV36HC-NBFH-W2	CV36HC-NBFH-S2	Case Cart, High, Clear Doors, Accessories, 2 Shelves	28 x 45.5 x 58.25	711 x 1156 x 1480



Solid Door Carts

Preconfigured Carts with Shelves, Accessories and 5th Wheel

Cat. No Wire Shelf	Cat. No Solid Shelf	Description	L x W x H (inch.)	L x W x H (mm)
CV36LS-5BFH-W1	CV36LS-5BFH-S1	Case Cart, Low, Solid Doors, 5th Wheel, Accessories, 1 Shelf	28 x 45.5 x 40.62	711 x 1156 x 1032
CV48LS-5BFH-W1	CV48LS-5BFH-S1	Case Cart, Low, Solid Doors, 5th Wheel, Accessories, 1 Shelf	28 x 57.5 x 40.62	711 x 1461 x 1032
CV36HS-5BFH-W2	CV36HS-5BFH-S2	Case Cart, High, Solid Doors, 5th Wheel, Accessories, 2 Shelves	28 x 45.5 x 58.25	711 x 1156 x 1480

Preconfigured Carts with Shelves and Accessories

Cat. No Wire Shelf	Cat. No Solid Shelf	Description	L x W x H (inch.)	L x W x H (mm)
CV24LS-NBF-W1	CV24LS-NBF-S1	Case Cart, Low, Solid Door, Accessories, 1 Shelf	28 x 33.5 x 40.62	711 x 851 x 1032
CV24LS-NBF-W1	CV24LS-NBF-S1	Case Cart, Low, Solid Door, Accessories, 1 Shelf	28 x 33.5 x 40.62	711 x 851 x 1032
CV24LS-NBF-W1	CV24LS-NBF-S1	Case Cart, Low, Solid Door, Accessories, 1 Shelf	28 x 33.5 x 40.62	711 x 851 x 1032
CV24LS-NBF-W1	CV24LS-NBF-S1	Case Cart, Low, Solid Door, Accessories, 1 Shelf	28 x 33.5 x 40.62	711 x 851 x 1032
CV24LS-NBF-W1	CV24LS-NBF-S1	Case Cart, Low, Solid Door, Accessories, 1 Shelf	28 x 33.5 x 40.62	711 x 851 x 1032



Flexline®



Flexline is constructed of advanced polymers, designed with rounded corners and infused with Microban antimicrobial product protection for a clean, durable solution that withstands the rigors of a laboratory environment.

- › Corrosion-proof, smooth, stain-resistant surfaces with rounded corners make cleaning quick and thorough.
- › Microban®* antimicrobial product protection is built in every cart, inhibiting the growth of mold, mildew and bacteria.
- › Available in pre-configured carts and build-a-cart components. To configure a cart to your exact specifications.



LAR Procedure
Cat. No.
FLISO1



General Storage
Cat. No.
FLTMENT2



LAR Procedure—
Tall Cat. No. **FLISO3**



General Storage
Cat. No. **FLBED**

Flexline® Polymer Enclosed Carts

Flexline Preconfigured Carts

Carts shown on the previous pages are configured with the components and accessories listed here.

Accessories

Description	FLISO1	FLISO3	FLBED	FLTMENT1	FLTMENT2	FLCAST
3" (76mm) Drawer Divider Kit		1			2	1
6/9" (152/229mm) Drawer Divider Kit		3			2	1
Side Bin (1) – Non Locking	2					4
Waste Basket 28 Quart & Holder						X
Glove Box Holder – Triple		X				
Pull Out Side Shelf		X				X
Auto Lock Keyless Entry Touch Pad				X		
Overbridge with 2 Shelves						X
Description						
36" (914mm) Cart – Passive Lock	X					
45" (1143mm) Cart – Passive Lock						X
45" (1143mm) Cart – Key Lock		X				
36" (914mm) Narrow Cart – Key Lock Drawer Pull Color			X	X		
	FL-YL	FL-YL	FL-VL	FL-GR	FL-SB	FL-OR
Description						
3" (76mm) Drawer		1	2	1	2	3
6" (152mm) Drawer	2		1	3	2	2
9" (229mm) Drawer	1	3	1		1	1



LAR Procedure
Cat. No.
FLTMENT1



LAR Procedure with
Overhead Package
Cat. No. FLCAST

FLEXLINE® BUILD-A-CART COMPONENTS



FLNK22100

Cart	Drawer Configuration	Lock	Drawer Pull Color	Cat. No.
36" (914mm) H Standard	2 - 3" (76mm)	Key Lock	Violet	FLK21100
	1 - 6" (152mm)			
	1 - 9" (229mm)			
36" (914mm) H Narrow	3 - 3" (76mm)	Key Lock	Pink	FLNK32000
	2 - 6" (152mm)			
39" (991mm) H Standard	3 - 3" (76mm)	Passive Lock	Red	FLP31100
	1 - 6" (152mm)			
	1 - 9" (229mm)			
42" (1067mm) H Narrow	2 - 3" (76mm)	Key Lock	Slate Blue	FLNK22100
	2 - 6" (152mm)			
	1 - 9" (229mm)			
42" (1067mm) H Standard	4 - 3" (76mm)	Passive Lock	Slate Blue	FLP41100
	1 - 6" (152mm)			
	1 - 9" (229mm)			
42" (1067mm) H Narrow	3 - 9" (229mm)	Key Lock	Dark Taupe	FLNK00300
45" (1143mm) H Standard	2 - 3" (76mm)	Passive Lock	Orange	FLP22010
	2 - 6" (152mm)			
	1 - 12" (305mm)			
45" (1143mm) H Narrow	1 - 3" (76mm)	Passive Lock	Green	FLNP13100
	3 - 6" (152mm)			
	1 - 9" (229mm)			

Suggested Carts with Drawers

Build-a-Cart

Nominal dimensions shown above

STANDARD CART

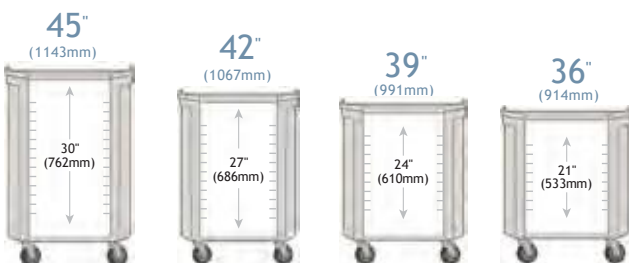

NARROW CART

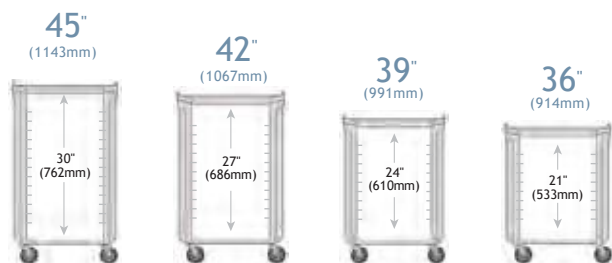

Literally, the lab of tomorrow.

STARSYS®

The Starsys Modular System creates flexible space.

No matter what you need — open, closed, short, tall, mobile, stationary elements, preconfigured WorkCenters or carts... Starsys has the elements for you.

With Starsys, you choose from an array of modular units to fit the space and work specifications.

It's that easy and that flexible.

Starsys Benefits:

- Flexibility to design a storage solution to meet your needs.
- Corrosion-proof polymer components for a contamination-free product.
- Durable, easy-to-clean, polymer enclosures that won't chip, dent, corrode or rust ever.
- Microban® antimicrobial protection inhibits the growth of stain and odor-causing bacteria on Starsys, keeping the surface areas "cleaner between cleanings."
- Rigid aluminum and epoxy-coated metal substructure combined with advanced polymers provide a robust work environment for even the most sensitive equipment.
- Facilitates fast, efficient product installation.
- The ability to easily reconfigure your furniture layout as needs change.
- A high level of compact organization with easy access to supplies.



Mobile WorkCenters



Tall Units



WorkCenters



Overheads



Carts

Research Lab . . .

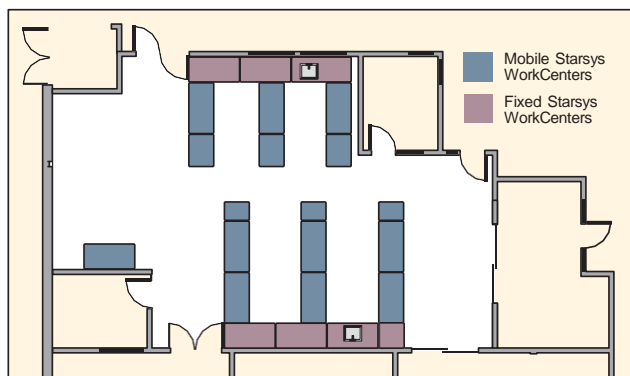

Research Lab, 5 minutes Later . . .

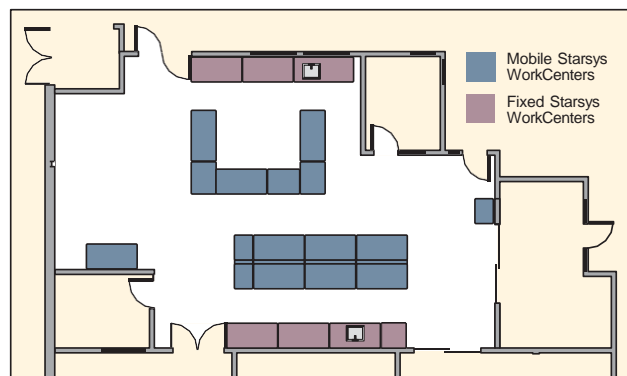

Starsys mobile products increase efficiency of your work space by adapting to the needed work environment and process workflow.

Starsys® Laboratory Furniture



Starsys Carts

Starsys provides a complete system of enclosed carts in a wide variety of heights and system widths. When mobility is a key part of your storage needs, Starsys carts provide a broad selection of unique solutions. This modular system approach allows you to create a cart to meet your exact needs.



Starsys Overhead Storage Solutions

The Starsys line offers two solutions when additional wall storage is required above a WorkCenter or when overhead storage is required above a Mobile WorkCenter.

Starsys Tambour Door Units: are not available in modular sizes, they have a fixed height, width & depth. The door, lock and bottom shelf are always included in the Tambour Door units. Accessories ship separate. Mounting hardware not included.

Starsys Half-Depth Overhead Storage Units: are built on the same widths as Starsys base units utilizing very similar construction, insuring that wall cabinets align with the lower product configuration in your application. Starsys Overhead Cabinets are available as single or double width cabinets



Starsys Mobile WorkCenters

Easily adapt to a changing work environment and even inspire change in your work environment. Starsys Mobile WorkCenters configurations have several kneewell and interior options.



Starsys WorkCenters

WorkCenters can be stand alone products or can be a configured section within a larger product configuration. WorkCenters combine valuable lower storage areas with finished modular countertops to offer a complete storage and work area solution.

Starsys WorkCenters are made up of two key components: base units and countertops. Understanding how these two elements work together is the key to understanding the Starsys WorkCenters line. While sections of Starsys WorkCenters can be configured into many physical combinations, these sections are typically divided into two categories: "straight run" or "corner" configurations.



Tall Stationary Units

Tall Stationary Units are stand-alone products or may be used in conjunction with other tall units or Starsys product families. Tall stationary units are available in single and double widths only.



Tall Mobile Units

Mobile units are available in single, double and triple widths. The overall height of a tall mobile unit is 78 1/3" (1990mm). Add 1 1/4" (299mm) with sloped tops. All units are 24 7/8" (632mm) deep.



CLEANER BY DESIGN™

- Microban® antimicrobial protection helps to keep products "cleaner between cleanings."
- Advanced polymer and other proprietary finishes provide corrosion resistance.
- Smooth, rounded corners to allow for easier cleaning.

*Microban protection is not designed to protect users against disease causing microorganisms.





Metro® stands alone.

Leading the industry in stability, mobility and efficiency.



<p>MetroMax® i Ultimate Lifetime Storage and Handling System.</p> <p>★★★★★ Corrosion Protection</p> <p>★★★★★ Cleanability</p> <p>★★★★★ Tear Resistance</p> <p>363kg (800lbs.) Shelf Capacity</p> <p>PROTECTION THAT LIVES ON MICROBAN</p>	<p>MetroMax® 4 Corrosion Proof with Unrivaled Value.</p> <p>★★★★★ Corrosion Protection</p> <p>★★★★★ Cleanability</p> <p>★★★★★ Tear Resistance</p> <p>272kg (600lbs.) Shelf Capacity</p> <p>PROTECTION THAT LIVES ON MICROBAN</p>	<p>MetroMax® Q Quick-to-Clean. Quick-to-Adjust.</p> <p>★★★★★ Corrosion Protection</p> <p>★★★★★ Cleanability</p> <p>★★★ Tear Resistance</p> <p>363kg (800lbs.) Shelf Capacity</p> <p>PROTECTION THAT LIVES ON MICROBAN</p>	<p>Super Erecta Pro® Durable & Cleanable. The Original...Reinnovated.</p> <p>★★★★★ Corrosion Protection</p> <p>★★★★★ Cleanability</p> <p>★★★ Tear Resistance</p> <p>363kg (800lbs.) Shelf Capacity</p> <p>PROTECTION THAT LIVES ON MICROBAN</p>	<p>Metroseal 3™ The Original Wire Shelving for Wet Environments.</p> <p>★★★ Corrosion Protection</p> <p>★★★ Cleanability</p> <p>★ Tear Resistance</p> <p>363kg (800lbs.) Shelf Capacity</p> <p>PROTECTION THAT LIVES ON MICROBAN</p>	<p>Chrome Plated & BRITE Basic Storage and Transport for Dry Environments.</p> <p>Dry Environments</p> <p>★★★ Cleanability</p> <p>★ Tear Resistance</p> <p>363kg (800lbs.) Shelf Capacity</p>	<p>Type 304 Stainless Steel Long Life Use in the Toughest Environments.</p> <p>★★★★★ Corrosion Protection</p> <p>★★★ Cleanability</p> <p>★ Tear Resistance</p> <p>363kg (800lbs.) Shelf Capacity</p>
--	---	--	--	---	---	--

Superior materials and design for every application.

Robust Corners and Frames • Proven Stability
Durable Finishes • Advanced Polymer Materials • Type 304 Stainless Steel Easy-to-Adjust in Increments of 1" (25mm)



MICROBAN® and the MICROBAN® symbol are registered trademarks of the Microban Products Company, Huntersville, NC.



SUPPORTS GOOD
HACCP
PROCESSES

Metro incorporates several elements in its product design to support cleaning protocols:



- Microban® antimicrobial product protection helps keep shelves “cleaner between cleanings” by inhibiting the growth of mold, mildew, fungus, and bacteria that cause odors and stains on the shelf surface.
- Advanced polymer and other proprietary finishes provide corrosion resistance.
- Smooth rounded corners to allow for easier cleaning.

Advantage Metro®

MetroMax® i:

The strongest, most versatile, corrosion proof shelving system in the world.



MetroMax® 4:

The Corrosion proof performance, proven Metro stability, and unrivaled value.



MetroMax® Q:

Quick adjustment, corrosion resistance and the strength of steel.



Super Adjustable Super Erecta®:

The easiest to adjust wire shelving system ever.

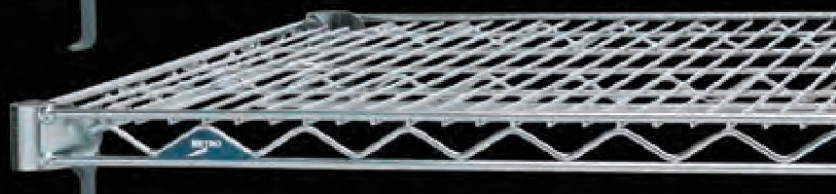

qwikSLOT®:

Add-A-Shelf, Remove-A-Shelf... Instantly.



Super Erecta Pro®:

Durable and Cleanable.
The original – reinnovated.



Super Erecta®:

The Original Wire Storage and Handling System.

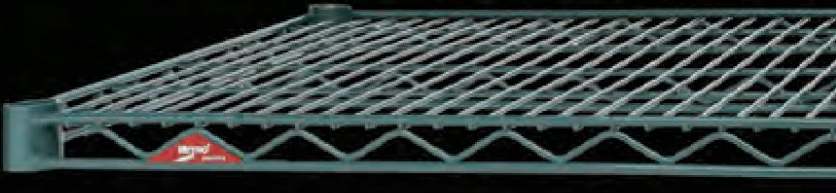

Drop Mat®:

Provides density and containment economically.



Super Erecta® Solid:

A solid performer in the proven Super Erecta style.



Metro's Advanced Products in Every Lab Environment

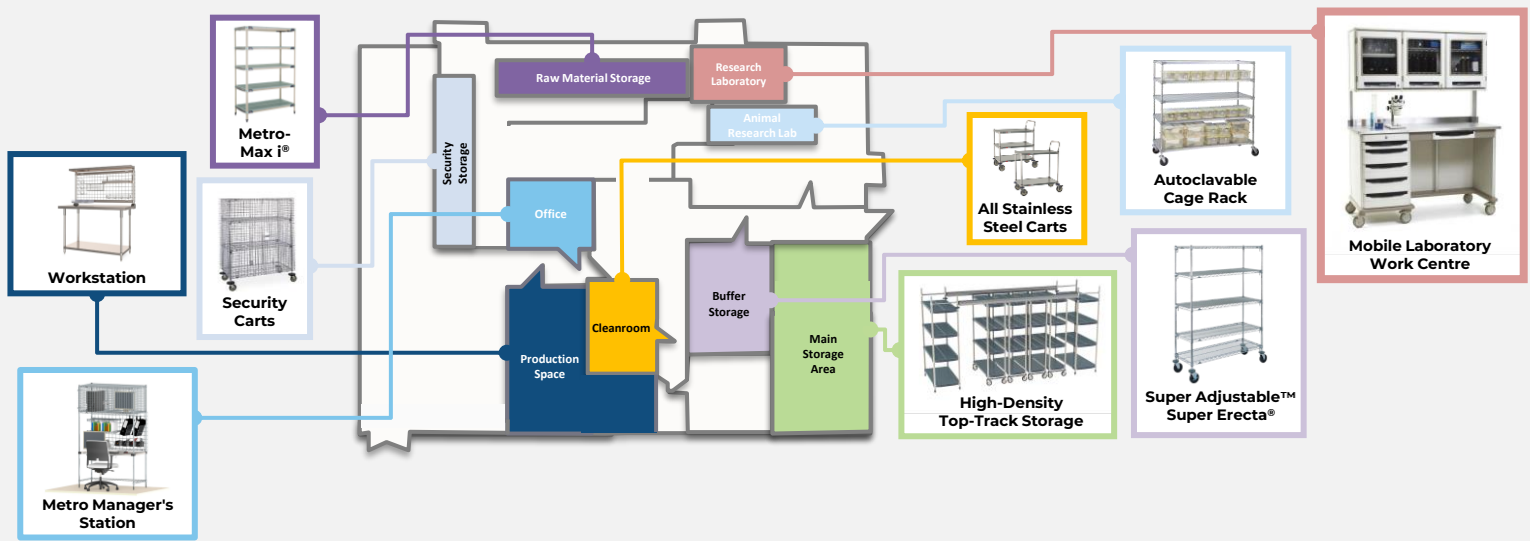

Metro® Has Got You Covered

Metro offers key products that can be easily implemented into any and every component of your facility. Our transport carts are suitable to connect the different sections of the complex.

Metro gives you the power to choose versatile

- cleanroom storage, transport, and workstation systems designed for optimal productivity.

Start clean, stay clean with genuine Metro

- products, ensuring easy-to-maintain hygiene and functionality.

Your Metro and Wachauf Industries Cleanroom

- Specialist can help you design a system to meet your exact requirements.

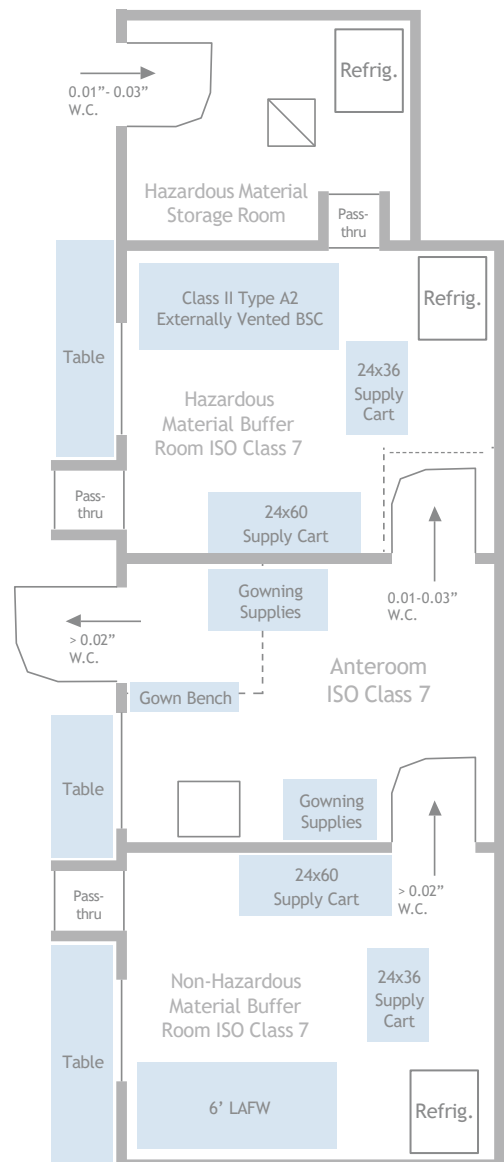



Contact Us

Address

2600 Vác,
Galcsek u. 8-10.
Hungary

Phone & Email

Tel: +36 27 502 555
Tel: +36 27 502 556
Email: sales@destsa.hu

Web

www.destsa.hu
www.dlb.hu